

# THEORY OF THE CURRENT IN A.C. POLAROGRAPHY

G. C. BARKER

*Atomic Energy Research Establishment, Harwell, England*

## INTRODUCTION

Originally a.c. polarography merely implied the study of the potential dependence of the periodically varying component of the cell current when the voltage applied to the electrodes of a polarographic cell has a small component varying sinusoidally with time<sup>1</sup>. The term today embraces many techniques, often related to the simple technique introduced by Breyer and coworkers<sup>1</sup> but differing from it in detail and in complexity of apparatus and theory. The value of many a.c. techniques in analytical work is recognised, but what is less well appreciated is the potential value of a.c. polarography for the study of electrode processes. However, the gap between polarography and the study of electrode processes has narrowed in the last two decades and this trend is likely to continue as the advantages offered by the dropping mercury electrode (d.m.e.), by automatic recording of data and by *in situ* formation of reactants find wider recognition. As more compact and more reliable a.c. polarographs of sophisticated design become available they may be used increasingly for the study of electrode processes as well as for purely analytical purposes. The former application demands a clear understanding of the factors influencing the impedance of the electrode-solution interface to alternating current. This impedance forms the subject of this paper but in view of the large number of "linear" and "non-linear" a.c. techniques already described and currently under development, no attempt will be made to derive expressions for the cell current when particular techniques are employed. Instead attention will be focused on aperiodic (valid for any single frequency or any combination of frequencies) equivalent electrical circuits for the faradaic part of the interfacial impedance and for the entire impedance, particular attention being given to the influence of reactant adsorption on the impedance.

The faradaic impedance has been studied theoretically by many workers — Warburg<sup>2</sup>, Frumkin and coworkers<sup>3</sup>, Randles<sup>4</sup>, Gerischer<sup>5</sup>, Vetter<sup>6</sup>, Tachi<sup>7</sup>, Delahay<sup>8</sup>, Matsuda<sup>9</sup>, Senda<sup>10</sup> and Lorenz<sup>11</sup>, to name but a few — and periodic (valid for any single frequency) equivalent circuits for some systems have been derived. Account has been taken of complications introduced by coupled chemical reactions, the diffuse double layer and specific adsorption of reactants. The treatments (for a review see ref. 8b) have usually led to explicit expressions for the faradaic current which although exact or reasonably exact solutions of the treated diffusion problems (taking account of only one complication at a time), give a somewhat diffuse picture of the faradaic impedance when, as is often the case, several complications

occur simultaneously. In the present paper a basically different approach to the interfacial impedance is outlined which casts new light on the anatomy of the impedance and makes it possible to deduce almost instantaneously an aperiodic equivalent circuit for a system of great complexity. Once such a circuit has been obtained it is often, but not invariably, a trivial step to proceed further to the derivation of an explicit expression for the cell current. Such circuits are also of considerable help when the theory of coulostatic, galvanostatic and potentiostatic relaxation techniques is under consideration provided the deviation of the potential from the equilibrium value is small.

### ASSUMPTIONS

All circuits appearing later refer to  $1 \text{ cm}^2$  of the electrode-solution interface. Any concentration ( $C_I$ ) usually is the mean or equilibrium value *at the interface* expressed in mole  $\text{cm}^{-3}$ . A circuit is valid in a case in which reactants are formed *in situ* at the surface of the d.m.e. only if the activation overpotential in the absence of the small alternating component of the potential is negligibly small.

Relative surface excesses ( $\Gamma_I$ ) of reactants are expressed in mole  $\text{cm}^{-2}$  and unless otherwise stated it is assumed that the Henry's law isotherm is obeyed and that consequently it is possible to write

$$\Gamma_I = \gamma_I C_I \quad (1)$$

where  $\gamma_I$ , the adsorption coefficient (cm) for reactant I, is a constant at constant potential. This assumption implies constancy of the activity coefficient of the reactant in its adsorbed state and hence low surface coverage. This is by no means an unrealistic simplification as several sensitive a.c. techniques make possible the use of exceptionally low reactant concentrations. It is further assumed that at all times the interface is in equilibrium with the two bulk phases *at the interface* as regards the *adsorption* of all components of these phases.

Reactants O and R in a charge transfer reaction which is formally written as

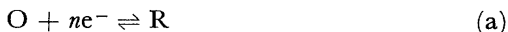

are assumed to be very minor constituents of the system and the supporting electrolyte concentration is supposed to be large enough to suppress electromigration in the neighbourhood of the interface connected with the diffuse double layer field. Mass transport of reactants by pure linear diffusion is assumed when the equilibrium between the phases is disturbed.

No specific assumptions are made about the nature of O or R which may be charged or uncharged entities. Usually O will be present in the solution but R may be located in either phase depending on the type of reaction. Reaction (a) and other coupled reactions may involve unmentioned reactants. If so, it is implicit that these additional reactants are present at sufficiently large concentration for all reactions to be treated as pseudo first order reactions.

The variation of the potential from the mean value or from the equilibrium value is taken to be minute in comparison with  $RT/nF$ , where  $R$ ,  $T$  and  $F$  have their usual significance.

### CHARGE UTILIZATION AT THE ELECTRODE-SOLUTION INTERFACE

So far few attempts have been made to discuss the thermodynamic theory of the electrode-solution interface when species present at the interface participate in an electrode reaction. Misconceptions about the theory are not difficult to find in the literature and therefore we start with a qualitative discussion of the way in which charge supplied to the electrode is utilised at the interface.

If the potential is suddenly made more negative then, as indicated schematically in *Figure 1*, cations of the supporting electrolyte tend to be transferred to the interface and anions of the supporting electrolyte present at the interface tend to be released into the solution. A transient current thus

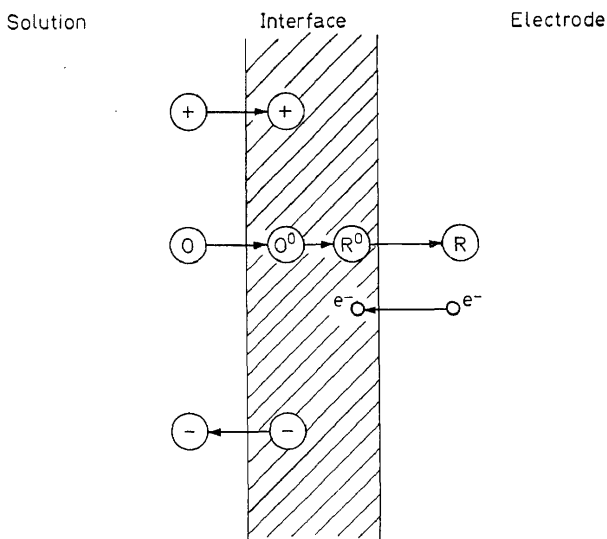

*Figure 1.* Motion of ions and reactants when the potential is changed

flows in the external circuit and this current is normally termed a non-faradaic current as it is connected solely with a change in the structure of the electrical double layer at the interface. If the solution also contains a reducible species O the change in potential may result in some reduction of O, forming R which may dissolve in the mercury phase. Additional current connected with this charge transfer reaction flows in the external circuit and this current is usually regarded as an independent current and is usually termed the faradaic current. The total current is the sum of these two supposedly independent currents. Unfortunately we find, if we look more deeply into this matter, that this artificial division of the current into two independent components has no strict thermodynamical basis although in cases where neither O nor R is adsorbed at the interface no errors are incurred by making such a division.

This result stems from our inability to establish by experiment the form of an adsorbed component at the interface. We can determine the relative

surface excesses of the various components of the system but it is impossible, unless a particular model is assumed, to arrive at any conclusions about their form in the interfacial region. Thus experiment might indicate that the specific adsorption of an iodide ion at constant potential is on the average accompanied by the removal of say 0.75 electrons from the mercury surface. This might mean that for some of the time the adsorbed ions are co-valently bound to the electrode and hence that part of the current flowing in the external circuit is connected with an electrode reaction. The current thus might be regarded as partly faradaic in nature. On the other hand it may be supposed that the charge on the adsorbed ions is unchanged at all times and that the current is purely non-faradaic in nature. Thermodynamic reasoning shows that we cannot distinguish by experiment between these two possibilities.

The reduction of O to R can be regarded as proceeding in three fairly distinct steps. First the adsorption of O forming an adsorbed entity which will be denoted by  $O^\circ$ . Next the conversion of  $O^\circ$  to  $R^\circ$ , using the latter symbol to denote adsorbed R, and finally the release of  $R^\circ$  from the interface producing reactant R dissolved in the mercury phase. Usually the first step in this sequence will lead to the transfer of some charge to or from the mercury surface and the associated current might be termed faradaic or non-faradaic depending on whether the charge on  $O^\circ$  is the same as that on O, a point which cannot be settled by experiment. Similar uncertainty about the classification of the current associated with the last of the two subsequent steps also exists and we thus see that if the cell current in polarography is to be divided into two parts for descriptive reasons more precise definitions of the two current components are needed.

In the present paper the "faradaic" current density is defined by equation (2) where  $\phi$  is the net rate (mole  $\text{cm}^{-2}\text{s}^{-1}$ ) of conversion of  $O^\circ$  into

$$i_f = -nF\phi \quad (2)$$

$R^\circ$ . The two adsorption steps are formally represented by the (hypothetical) charge transfer reactions (b) and (c) which do no more than indicate that,



on the average,  $a$  and  $b$  electrons respectively are supplied to the electrode when, at constant potential, one molecule of O is adsorbed from the solution and one molecule of R is desorbed into the phase containing reactant R. The signs of  $a$  and  $b$  depend on the signs of  $(d\gamma_0/dE)_{C_0}$  and  $(d\gamma_R/dE)_{C_R}$ . The "non-faradaic" current density  $i_{\text{nf}}$  is given at all times by Eq. (3) where  $C_{d1}$

$$i_{\text{nf}} = C_{d1} \frac{dE}{dt} - aF \frac{d\Gamma_0}{dt} + bF \frac{d\Gamma_R}{dt} \quad (3)$$

is strictly the differential capacity for constant  $\Gamma_0$  and  $\Gamma_R$ , i.e.  $(dq/dE)_{\Gamma_0, \Gamma_R}$  where  $q$  is the charge density on the mercury surface.† For low values of the surface excesses it readily follows from the Gibbs adsorption isotherm that this capacity differs little from the capacity at the same potential in the

†  $C_{d1}$  may alternatively be regarded as the differential capacity at infinite frequency.

## THEORY OF THE CURRENT IN A.C. POLAROGRAPHY

absence of components O and R if the two adsorption coefficients  $\gamma_O$  and  $\gamma_R$  are large and not greatly potential dependent. The total current density is

$$i = i_f + i_{nf} \quad (4)$$

The assumption of equilibrium at the interface for reactions (b) and (c) simplifies the analysis of the "faradaic" part of the interfacial impedance as it is possible to ignore these reactions completely and consider simply the impedance associated with the overall reaction (a). If this is done, the surface excesses of reactants must not be ignored when the parts of the impedance connected with the diffusion of reactants are being considered. Also, it has to be borne in mind that any rate constants and transfer coefficients will be only apparent parameters. For example if this procedure is followed, for the rate of reduction of O we write  $k_f C_O$  where  $k_f$  is an apparent charge transfer rate constant, whereas we should write  $k'_f T_O$  where  $k'_f$  is the real rate constant. If accurate adsorption data are available it is a simple matter to deduce the actual rate constants from apparent values referred to reactants O or R. If the variation of adsorption coefficients with potential is known it is possible also to calculate the actual transfer coefficients. Thus there is no need initially to take account of the detailed mechanism in so far as the faradaic part of the impedance is concerned. The adsorption steps must, however, be allowed for when the non-faradaic part is being considered, though in practice the effect of reactant adsorption on this part of the impedance is often much less important than its influence on the faradaic part.

### SIMPLE CHARGE TRANSFER REACTION

We consider first the aperiodic circuit for the faradaic impedance associated with the simple charge transfer reaction

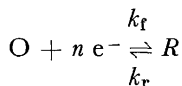

when the system is initially at equilibrium and this equilibrium is slightly disturbed by a small aperiodic change of potential. The total overpotential  $\Delta E$  when the system is not at equilibrium is the sum of terms due to mass transport polarization and an activation overpotential. The faradaic current density is given by Eq. (5) where  $C_O(t)$  and  $C_R(t)$  are concentrations of

$$i_f = - nF [k_f C_O(t) \exp(-\alpha \Delta E nF / RT) - k_r C_R(t) \exp(1 - \alpha) \Delta E nF / RT] \quad (5)$$

reactants at the interface at the time in question, the (apparent) rate constants  $k_f$  and  $k_r$  refer to the initial equilibrium state and  $\alpha$  is the (apparent) transfer coefficient of the forward process, the reduction of O. This equation, after writing  $C_O + \Delta C_O$  for  $C_O(t)$  and  $C_R + \Delta C_R$  for  $C_R(t)$  where  $C_O$  and  $C_R$  are equilibrium values, expanding the exponentials and dropping terms of high order, can be written in the form

$$\Delta E \simeq \frac{RT}{nF} \frac{\Delta C_O}{C_O} - \frac{RT}{nF} \frac{\Delta C_R}{C_R} + \frac{RT}{n^2 F^2 k_f C_O} \times i_f \quad \left( \Delta E \ll \frac{RT}{nF} \right) \quad (6)$$

The first term on the right hand side of this equation is the change in the

“instantaneous” equilibrium potential due to the small change in the concentration of reactant O at the interface. The second term is the corresponding change due to the change in the concentration of R and the last term is the activation overpotential due to the irreversibility of the charge transfer reaction. Thus at all times the total overpotential  $\Delta E$  can be regarded as the sum of three independent components which we will denote by  $\Delta E_O$ ,  $\Delta E_R$  and  $\Delta E_{ct}$ . We expect the equivalent circuit to consist of three parts connected in series as indicated in Figure 2(a) since each component of the overpotential is linearly related to the magnitude of  $i_t$  if all other factors

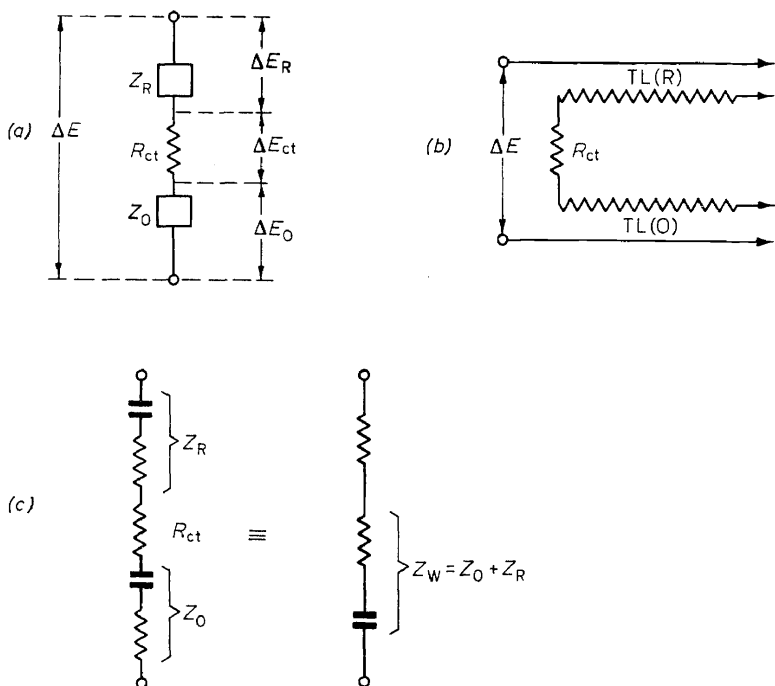

Figure 2. Equivalent circuits for the faradaic impedance: (a) elementary circuit; (b) aperiodic circuit; (c) periodic circuit

remain constant and the condition  $\Delta E \ll RT/nF$  is satisfied. The impedances  $Z_O$  and  $Z_R$  across which the potential components  $\Delta E_O$  and  $\Delta E_R$  appear in this elementary circuit are often termed the diffusion impedances for reactants O and R respectively.

It follows from the last term in Eq. (6) that

$$\Delta E_{ct} = \frac{RT}{n^2 F^2 k_t C_O} \times i_t \quad (7)$$

and thus irreversibility is represented in the circuit for the faradaic impedance by a charge transfer resistance  $R_{ct}$  defined by Eq. (8), where  $\Theta = n^2 F^2 / RT$ .

$$R_{ct} = \frac{1}{\Theta k_t C_O} = \frac{1}{\Theta k_r C_R} \quad (8)$$

## THEORY OF THE CURRENT IN A.C. POLAROGRAPHY

The impedances  $Z_O$  and  $Z_R$  are dependent on the way in which the reactants are transported to and from the interface and we now proceed to ascertain their form when only pure linear diffusion is involved. This we can do most readily by taking note of the fact that the linear diffusion of a reactant in a semi-infinite medium is the analogue of charge diffusion along a special type of transmission line. One of the conductors of this line has uniform series resistance  $R_{TL}$  per unit length and the line has uniform shunt capacity  $C_{TL}$  per unit length between the resistive conductor and a perfect conductor (the base of the line) running parallel to the resistive conductor. The line contains no inductance, is of virtually infinite length and in an electrical circuit it is best represented by a conductor running close to and parallel to a resistance.

The equation for the linear diffusion of reactant I ( $I = O, R, \text{etc}$ ) in the unsteady state is

$$\frac{\delta C_I(x,t)}{\delta t} = D_I \frac{\delta^2 C_I(x,t)}{\delta x^2} \quad (9)$$

where  $D_I$  is the diffusion coefficient and  $C_I(x,t)$  refers to the plane  $x$ . The analogous equation for charge diffusion along the transmission line TL is

$$\frac{\delta V(x,t)}{\delta t} = \frac{1}{R_{TL}C_{TL}} \frac{\delta^2 V(x,t)}{\delta x^2} \quad (10)$$

and it is not difficult to show that if

$$C_{TL(I)} = \Theta C_I \text{ (farad cm}^{-1}\text{)} \quad (11)$$

and

$$R_{TL(I)} = \frac{1}{\Theta C_I D_I} \text{ (ohm cm)} \quad (12)$$

the voltage developed between the input terminals of the line will equal  $|\Delta E_I|$  and any change in the voltage across the line (referred to the steady state value) at distance  $x$  from the input terminals will numerically equal  $RT/nFC_I$  times the change in the concentration of the reactant at a plane distance  $x$  from the electrode surface. The voltage across the line is thus simply related to the concentration at the corresponding plane in the electrochemical diffusion system.

Strictly in the initial equilibrium state the line voltage will be finite if the diffusion of reactant I is to be represented by the diffusion of electrical charge along a line. However, we are most interested in changes of concentration and the line can be regarded as uncharged when the system is at equilibrium. Thus we see that the unknown impedances  $Z_O$  and  $Z_R$  in *Figure 2(a)* are transmission lines of virtually infinite length. Provided that the frequency is not so large as to render our assumption of pure linear diffusion invalid (in reality charge transfer seldom can be strictly assumed to take place with equal probability at all points on the electrode surface and at very high frequencies hemispherical diffusion centred on species adsorbed at the interface may become important) the complete aperiodic circuit for the faradaic impedance is the one in *Figure 2(b)* where the lines

TL(O) and TL(R) are defined by Eqs. (11) and (12). TL(R) is inverted in order that the line voltage (the voltage with respect to the base of the line) shall be of the same sign as the change in the concentration of R at the corresponding plane. The overpotential is thus developed between the bases of the two lines. It should be mentioned that the charge stored in any short length of line is equal to  $nF$  times the change in the amount of the reactant in question in the corresponding region of the electrochemical system.

This aperiodic circuit is valid however  $\Delta E$  may change with time provided the deviation of the potential from the equilibrium (or mean) value is small. When the potential varies sinusoidally it follows from standard transmission line theory that the input impedance of a line associated with linear diffusion is at angular frequency  $\omega$

$$\begin{aligned} Z_{\text{TL(I)}} &= [R_{\text{TL(I)}}/j\omega C_{\text{TL(I)}}]^{\frac{1}{2}} && \text{where I = O,R} \\ &= [R_{\text{TL(I)}}/2\omega C_{\text{TL(I)}}]^{\frac{1}{2}} [1 + (1/j)] \end{aligned} \quad (13)$$

Thus, as indicated in *Figure 2(c)*, in the periodic circuit for the faradaic impedance each line can be replaced by a capacity and a resistance connected in series, and, after combining the new resistances and capacities, the periodic circuit consists of the charge transfer resistance  $R_{\text{ct}}$  in series with a capacity and a resistance. The latter two components together exhibit a phase angle of  $45^\circ$  and are sometimes termed the Warburg impedance or the diffusion impedance of the system.

An explicit expression for the faradaic impedance at angular frequency  $\omega$  readily follows from equations already given and is identical with that obtained by more conventional methods. Clearly the approach to the faradaic impedance just outlined offers no substantial advantages over normal analytical methods in the case of a simple reaction. It is with more complex systems that the real benefits of the present approach are felt and, although it is not our intention to consider systems of outstanding complexity, it is desirable perhaps to illustrate this point by considering briefly the influence of several complications on the circuit for the faradaic impedance before turning to the effects of reactant adsorption.

### COUPLED CHEMICAL REACTIONS AND PARALLEL CHARGE TRANSFER REACTIONS

We have seen that the linear diffusion of a reactant is represented in the aperiodic circuit for the faradaic impedance by a simple transmission line. Let us now suppose that reactant O exists in solution in two forms O and  $O_p$ , the latter reactant being the precursor of O. For the homogeneous chemical reaction we write simply



At first it will be supposed that the interconversion of O and  $O_p$  proceeds very slowly in the solution but that both entities are readily reduced at the interface forming R, so that initially the system is at equilibrium, the equilibrium being established by way of the charge transfer reactions. This more complex system can be treated in exactly the same way as the

THEORY OF THE CURRENT IN A.C. POLAROGRAPHY

simple system just considered and one then finds that the aperiodic circuit contains all the components of the previous circuit and in addition two new components. One of these is a transmission line  $TL(O_p)$  defined by Eqs. (11) and (12), the base of which is connected to the base of  $TL(O)$  (see Figure 3). The other is a second charge transfer resistance  $R_{ctO_p}$  defined by an equation analogous to (8). This resistance not unexpectedly links the resistive conductor of the new line  $TL(O_p)$  with the resistive conductor of  $TL(R)$ .

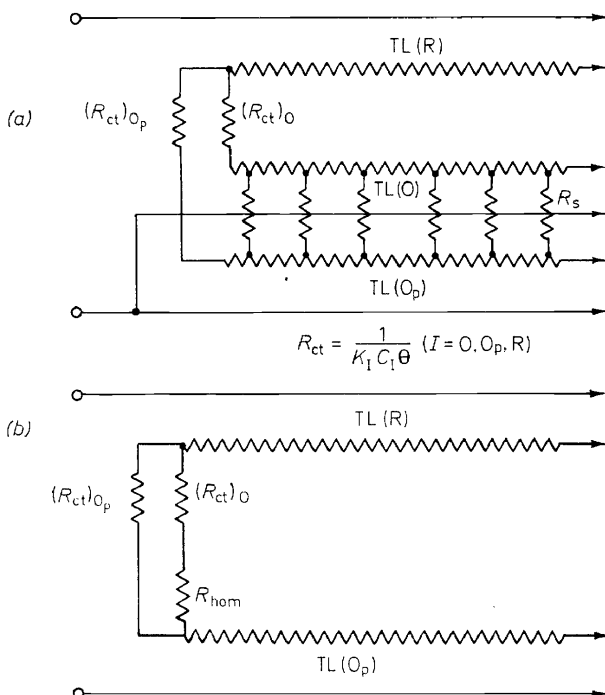

Figure 3. Coupled chemical reaction, parallel charge transfer reactions: (a) general circuit; (b) circuit when  $C_O \ll C_{O_p}$

It is thus easy to make allowance for two parallel charge transfer reactions involving the same number of electrons and leading to the formation of a common reactant. Additional parallel reactions of the same type would merely require the introduction of further lines and further charge transfer resistances. It is invariably a simple matter in such cases to derive an expression for the impedance when the variation of potential with time is sinusoidal.

The next step is to "unfreeze" the homogeneous chemical reaction and allow the conversion of  $O$  into  $O_p$  and the reverse process to take place in the solution near the electrode. For a small disturbance of the equilibrium we find that at plane  $x$  the net rate of conversion of  $O_p$  into  $O$  is  $C_{O_p} k_d [\Delta C_{O_p}(x)/C_{O_p} - \Delta C_O(x)/C_O]$  where  $\Delta C_{O_p}(x)$  and  $\Delta C_O(x)$  are the deviations of the concentrations of reactants  $O_p$  and  $O$  at plane  $x$  from the equilibrium values  $C_{O_p}$  and  $C_O$ . Now  $\Delta C_{O_p}(x)/C_{O_p} = V_{O_p} nF/RT$  and  $\Delta C_O(x)/C_O = V_O nF/RT$  where  $V_{O_p}$  and  $V_O$  are the line voltages at distance  $x$  from the input

terminals. It readily follows that the homogeneous reaction can be allowed for exactly (small deviation of  $E$  from the equilibrium value) by uniform resistance linking the resistive conductors of  $\text{TL}(\text{O}_p)$  and  $\text{TL}(\text{O})$  where the linking resistance per unit length is defined by

$$R_s = \frac{1}{\Theta k_d C_{\text{O}_p}} \quad (14)$$

The final circuit for this system is thus the one shown in *Figure 3(a)*. It is quite complex and it is not always easy, if the contributions of  $\text{TL}(\text{O}_p)$  and  $\text{TL}(\text{O})$  to the impedance are of comparable magnitude, to proceed further to the derivation of an explicit expression for the periodic impedance, (unless  $R_s$  is relatively large). However, if  $C_{\text{O}}$  is considerably smaller than  $C_{\text{O}_p}$ , a case which is occasionally encountered with solutions containing complexing ions, the circuit reduces to the approximate circuit in *Figure 3(b)*. In this "kinetic" case the interconversion of  $\text{O}$  and  $\text{O}_p$  is confined to a thin reaction layer near the electrode and if the input impedance of  $\text{TL}(\text{O})$  is large compared with the resistance  $R_{\text{hom}}$  in this approximate circuit, the latter circuit describes fairly well the behaviour of the system. The resistance  $R_{\text{hom}}$  is evaluated by treating the resistive conductor of  $\text{TL}(\text{O}_p)$  as a perfect conductor and then transmission line theory indicates that the resistive conductor of  $\text{TL}(\text{O})$  and the distributed resistance linking this conductor with  $\text{TL}(\text{O}_p)$  can be replaced by the resistor  $R_{\text{hom}}$  where

$$R_{\text{hom}} \cong [R_{\text{TL}(\text{O})} R_s]^{\frac{1}{2}} = \theta^{-1} [D_{\text{O}} C_{\text{O}} k_d C_{\text{O}_p}]^{-\frac{1}{2}} \quad (15)$$

Systems with coupled chemical reactions are invariably the most difficult to handle whatever approach may be employed but there is still something to be gained by considering first the form of the aperiodic circuit as it indicates immediately those parts of the diffusion problem that can only be solved by conventional analytical methods. In the case of the system just considered we see for example that if  $R_{\text{etO}_p}$  can be ignored a conventional approach is only needed to obtain a two terminal circuit equivalent to that part of the aperiodic circuit representing the linear diffusion of  $\text{O}_p$  and  $\text{O}$  and the chemical reaction. In this case use can be made of results given by Gerischer<sup>5</sup> and an explicit expression for the faradaic impedance at angular frequency  $\omega$  readily follows (taking account possibly of other complications considered later such as reactant adsorption at the interface).

### CONSECUTIVE CHARGE TRANSFER REACTIONS

Consecutive charge transfer reactions by way of contrast present few difficulties. The procedure in the case of the simple reaction scheme

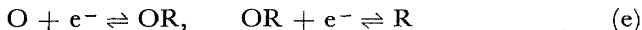

is to assume first that the two reactions are completely independent and to deduce aperiodic circuits for the two faradaic impedances. It is found that the circuits have a common component  $\text{TL}(\text{OR})$  and thus it is to be expected that the circuit when the reactions are coupled will be obtained by "fusing" the two circuits at the common component  $\text{TL}(\text{OR})$ . The resulting circuit is shown in *Figure 4(a)*. It contains a new circuit component, an ideal transformer, to allow for the simultaneous effect of the overpotential on

THEORY OF THE CURRENT IN A.C. POLAROGRAPHY

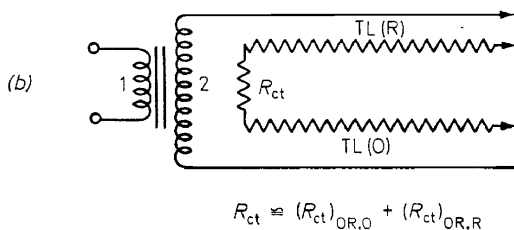
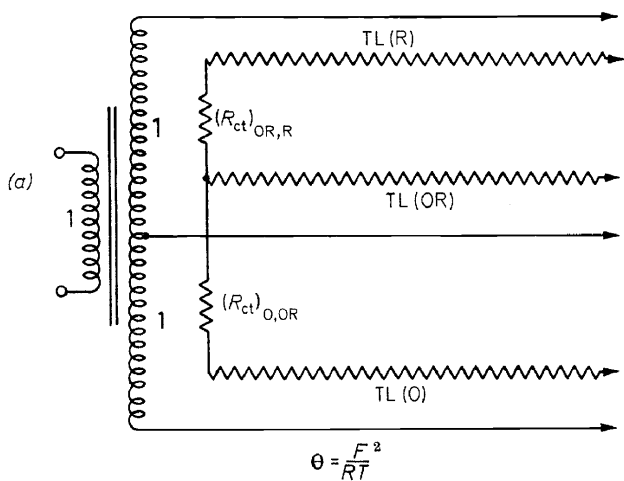

Figure 4. Coupled charge transfer reactions,  $O + e^- \rightleftharpoons OR$ ,  $OR + e^- \rightleftharpoons R$ : (a) general form of circuit; (b) circuit for  $C_{OR} \ll C_O$ ,  $C_{OR} \ll C_R$  when  $R_{ct}$  is small

both charge transfer reactions. In this case, where each reaction involves only one electron, the transformer ratio for each half of the secondary winding is unity. If the reactant  $OR$  is a minor constituent of the system  $TL(OR)$  often can be disregarded and the circuit reduces to the one shown in Figure 4(b). This circuit has essentially the same form as that for the single reaction  $O + ne \rightleftharpoons R$  but the charge transfer resistance is now differently defined and may vary in a rather different way with the equilibrium potential. The transmission lines and charge transfer resistances in the circuits shown in Figure 4 are of course defined by Eqs. (8), (11) and (12).

**ADSORPTION OF REACTANTS**

Turning now to the influence of specific adsorption of one or both reactants it is first necessary to recall that if linear diffusion of a reactant is represented in an equivalent circuit by a resistive transmission line, the charge stored in any portion of the line is usually numerically equal to the electrical charge required to produce electrochemically the excess or deficit of the reactant in the corresponding part of the electrochemical diffusion system

when the system is not at equilibrium†. Also, that  $C_{TL(I)}$  the shunt capacity per unit length equals  $\theta C_I$ , where  $C_I$  is the reactant concentration at equilibrium. So far we have been considering systems in which the concentration throughout a phase is uniform when the system is in equilibrium. This is not always the case. For instance, if a diffuse double layer is introduced into the picture it may be supposed that at equilibrium the reactant concentration is  $C_I^* \exp(z\psi F/RT)$  where  $\psi$  is the potential with respect to the bulk of the phase,  $z$  is the number of electronic charges carried by the reactant and  $C_I^*$  is the concentration at a plane sufficiently far from the interface for  $\psi$  to vanish. In this case if we look more deeply into the diffusion problem, we find that the earlier expression for  $C_{TL}$  still holds but  $C_I$  must now be identified with the equilibrium concentration at the plane in question. Thus when the diffuse double layer cannot be ignored the capacity per unit length may increase or decrease progressively as the input terminals are approached depending on whether the reactant is attracted to or repelled from the interface. A small positive surface excess associated with non-specific adsorption thus should strictly be allowed for by introducing additional distributed shunt capacity in the part of the line representing the diffuse double layer. The diffuse double layer also affects the series resistance of the line but this point will not be discussed.

The line capacity for a given charge transfer reaction thus is determined by the amount of the reactant present in the corresponding region of the electrochemical system when the system is at equilibrium (or in a pseudo equilibrium state). If in any region the *apparent* activity coefficient of the reactant changes there must invariably be a change in shunt capacity in the corresponding part of the transmission line. Thus in a hypothetical case in which the equilibrium concentration is enhanced in the region between the planes  $x_1$  and  $x_2$  (due perhaps to a film of ion exchange resin), as indicated in *Figure 5(b)* additional shunt capacity would be added to the transmission line from a point distance  $x_1$  to one distance  $x_2$  from the input terminals.

It is clear that a surface excess (positive or negative) of a reactant produced by non-specific or specific adsorption must be represented in the equivalent circuit (*Figure 5c*) by what will be termed an adsorption capacity  $C(I)$  defined by

$$C(I) = \theta \Gamma_I \quad (16)$$

where  $\Gamma_I$  is the surface excess. If the adsorption is non-specific this additional positive or negative capacity should strictly be distributed over the part of the line representing the diffuse double layer but as the thickness of the layer is so small no significant error is introduced by connecting the adsorption capacity between the input terminals of the line. It should be noted that the charge stored in the adsorption capacity is equal to  $nF\Delta\Gamma_I$  where  $\Delta\Gamma_I$  is the change in the surface excess in the non-equilibrium state†.

If there is positive adsorption of a reactant, it is evident that it will be more difficult to change the concentration of this reactant near the electrode surface. In other words the apparent diffusion impedance for the reactant is lowered and this is allowed for in the aperiodic circuit by shunting the usual

† This may not be true if the circuit contains a transformer.

THEORY OF THE CURRENT IN A.C. POLAROGRAPHY

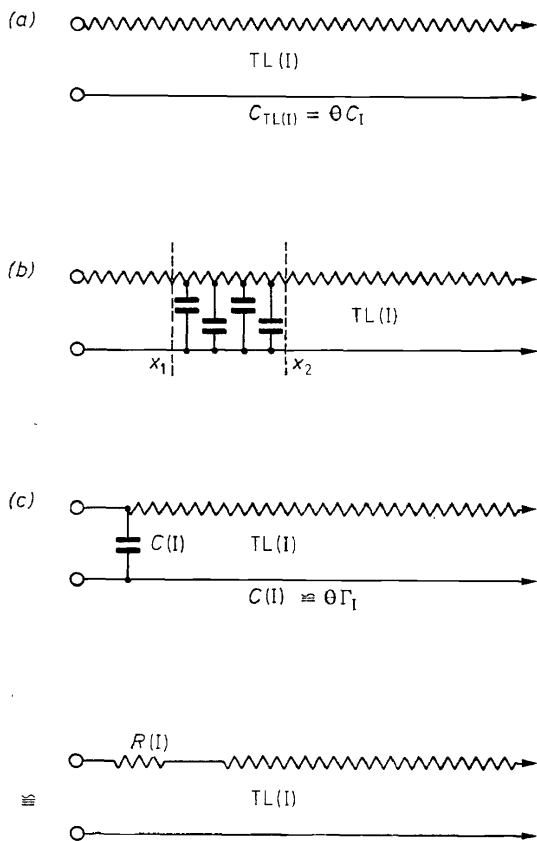

Figure 5. Influence of reactant concentration on the diffusion impedance: (a) circuit for linear diffusion of I; (b) uneven reactant concentration in solution; (c) adsorption of reactant I at interface.

linear diffusion transmission line with an adsorption capacity. It is not difficult to show that the behaviour of the resulting circuit, when the adsorption coefficient is considerably smaller than the thickness of the region in which the reactant concentration is disturbed, is virtually the same as that when the adsorption capacity is replaced by a negative resistance  $R(I)$  connected in series with the line, (Figure 5c) if

$$\begin{aligned}
 R(I) &= -\gamma_I R_{TL(I)} \\
 &= -\gamma_I / \theta C_I D_I
 \end{aligned}
 \tag{17}$$

This simple circuit transformation often is of value when charge transfer irreversibility is combined with specific adsorption.

So far our treatment of specific adsorption has been inexact in that account has only been taken of the dependence of the surface excess on  $C_I$ , the reactant concentration at the interface. No allowance has been made for the finite value of  $(d\gamma_I/dE)_{C_I}$ . This defect, although seldom a particularly serious one, will be remedied in the following section.

## EQUIVALENT CIRCUIT FOR THE INTERFACIAL IMPEDANCE

We are now in a position to construct an aperiodic equivalent circuit for the entire interfacial impedance and in the case of the three step reaction mentioned earlier it takes the form shown in *Figure 6*. The faradaic part of the impedance comprises the two transmission lines TL(O) and TL(R)

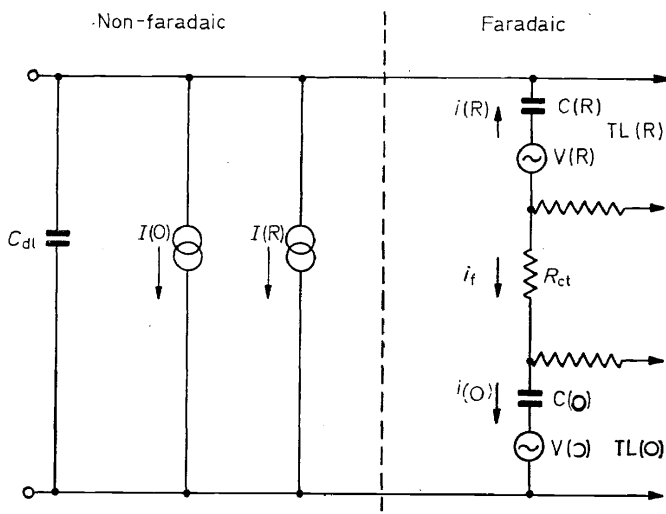

*Figure 6.* Aperiodic equivalent circuit for the interface when reactants O and R are strongly adsorbed but  $\Gamma_O$  and  $\Gamma_R$  are small

[defined by Eqs. (11) and (12)] which are shunted by adsorption capacities  $C(O)$  and  $C(R)$  defined by Eq. (16) and linked by a charge transfer resistance  $R_{ct}$  defined by Eq. (8). If it is supposed that  $(d\gamma_I/dE)_{C_I} = 0$  for both reactants then the charge transfer numbers  $a$  and  $b$  for the two adsorption steps [reactions (b) and (c)] both equal zero and the circuit is completed by connecting the differential capacity  $C_{dl}$  across the faradaic part of the impedance. As indicated earlier  $C_{dl} = (dq/dE)_{\Gamma_O, \Gamma_R}$ .

However, more generally  $(d\gamma_I/dE)_{C_I}$  is finite and allowance should be made for (a) the *direct* effect of potential on the surface excesses, and (b) non-faradaic current connected with the adsorption steps as the charge transfer numbers  $a$  and  $b$  are now finite in value. Considering first the changes in the faradaic part of the impedance, we have earlier noted that the charge stored in an adsorption capacity equals  $nF$  times the change in the surface excess. This is a strict equality which must always be satisfied whatever the cause of the change in the surface excess. If the adsorption coefficient is potential dependent it can be satisfied by inserting in series with the adsorption capacity a voltage generator which supplies a small (positive or negative) fraction of the total overpotential  $\Delta E$ . Thus two voltage generators  $V(O)$  and  $V(R)$  have to be inserted in the faradaic part of the circuit in the positions indicated in *Figure 6*, and it is readily found that

$$V(I) = -\frac{RT}{nF} \left( \frac{d \ln \gamma_I}{dE} \right)_{C_I} \Delta E \quad (18)$$

where  $V(I)$  is the voltage with respect to the generator terminal closest to the base of the associated line. What we term the "faradaic" part of the circuit is now complete.

The "non-faradaic" part of the circuit must satisfy equation (3) and the charge transfer numbers connected with the two adsorption steps have to be more precisely defined. Making the assumptions mentioned earlier and assuming also that the adsorption coefficients for the reactants greatly exceed the integral adsorption coefficients ( $\Gamma_x/C_x$ ), for ions of the supporting electrolyte, it follows from the Gibbs adsorption isotherm that  $q$ , the charge density on the mercury surface is given by

$$q \cong q_{se} + RT \left( \frac{d\Gamma_0}{dE} \right)_{C_0} \quad (19)$$

if the system contains only reactant O. In this equation  $q_{se}$  is the corresponding charge density when component O is absent. As the adsorption coefficient is supposed to be a constant at constant potential, Eq. (19) can be written in the form

$$q \cong q_{se} + RT\Gamma_0 \left( \frac{d \ln \gamma_0}{dE} \right)_{C_0}$$

Hence

$$\left( \frac{dq}{d\Gamma_0} \right)_E \cong RT \left( \frac{d \ln \gamma_0}{dE} \right)_{C_0} \quad (20)$$

As low surface coverage is assumed for both adsorbed O and adsorbed R we expect Eq. (20) to be valid when the system contains R and the electrode reaction takes place at the interface. Thus the fractional charge transfer number appearing in adsorption reaction (b) is defined by

$$a \cong -\frac{RT}{F} \left( \frac{d \ln \gamma_0}{dE} \right)_{C_0} \quad (21)$$

and with a change of sign  $b$  is given by an analogous equation. These results we can check by treating each adsorption step as a real charge transfer reaction involving a fractional number of electrons. For example, writing

$$E \cong E_0 + \frac{RT}{aF} \ln \frac{C_0}{\Gamma_0} \quad (22)$$

where  $E_0$  is a type of standard potential and differentiating with respect to potential holding  $C_0$  constant, Eq. (21) is again obtained.

As the transfer of molecules of O from the solution to the interface involves the supply of electrons to the electrode and the rate of transfer is linked to the current flowing into the adsorption capacity  $C(O)$ , it is evident that the non-faradaic current associated with changes in  $\Gamma_0$  with time can be accurately represented in the equivalent circuit by an infinite impedance current generator  $I(O)$  connected across the faradaic part of the circuit.

The dependence of  $q$  on  $\Gamma_R$  is likewise represented by a current generator  $I(R)$ , and the differential capacity  $C_{dl}$  takes account of changes in  $q$  due solely to changes in  $q_{se}$  with potential. The currents supplied by  $I(O)$  and  $I(R)$  are proportional at all times to the currents  $i(O)$  and  $i(R)$ , respectively, flowing through  $C(O)$  and  $C(R)$  and in *Figure 6* the directions of linked currents are indicated by arrows. The following equation relates  $I(I)$  with  $i(I)$ †

$$I(I) = \frac{RT}{nF} \left( \frac{d \ln \gamma_I}{dE} \right)_{C_I} \times i(I) \quad (23)$$

Apart from the inclusion of the two voltage generators the final circuit is identical with one advanced some years ago<sup>12, 10</sup>. The latter circuit is often sufficiently accurate since adsorption coefficients frequently vary quite slowly with potential and hence, without incurring serious errors, the voltage and the current generators in the circuit in *Figure 6* often can be ignored.

The system just considered with simultaneous adsorption of both reactants has recently been studied theoretically by Delahay and Susbilles<sup>13</sup>. The basic assumptions made by these workers resemble those made here although their treatment follows conventional lines and leads to rather complex expressions for the resistive and reactive parts of the impedance at angular frequency  $\omega$ . Some measure of agreement between their findings and conclusions to be drawn from the circuit in *Figure 6* would be expected. In fact it can be shown that if in the treatment of these workers the variations of the surface excesses and  $q$  are more rigorously allowed for the two approaches lead to identical results at least when the surface excesses are small but  $\gamma_O$  and  $\gamma_R$  are large.

### INFLUENCE OF REACTANT ADSORPTION ON THE ELECTROCAPILLARY CURVE

Strong adsorption of one or both reactants tends to lower the surface tension of the mercury surface and in the vicinity of the half-wave potential a break in the curve may be observed due to changing reactant concentrations at the interface. *Figure 7* shows schematically the variation of the surface tension  $\sigma$  with potential, and also the variations of  $(d\sigma/dE)_{\Sigma CD \ddagger}$  and  $(d^2\sigma/dE^2)_{\Sigma CD \ddagger}$ , in a case in which reactant R is not adsorbed. To simplify the discussion it is assumed that the adsorption of O is not *directly* potential dependent, i.e.  $(d\Gamma_O/dE)_{C_O} = 0$ . At potentials appreciably more positive than the half-wave potential  $E_{\frac{1}{2}}$ , the surface tension is uniformly lowered. At potentials more negative than  $E_{\frac{1}{2}}$ , the surface tension curve coincides with that for the base solution. The derivative of  $\sigma$  with respect to potential passes through zero three times and it might be supposed, by analogy with the perfectly polarizable electrode, that at three different potentials the double layer charge density is zero. Such, however, is not the case. The quantity

† If  $\gamma_O$  and  $\gamma_R$  are small, Eq. (23) must be replaced by

$$I(I) = \frac{1}{nF} \left( \frac{dq}{d\Gamma_I} \right)_E \times i(I)$$

## THEORY OF THE CURRENT IN A.C. POLAROGRAPHY

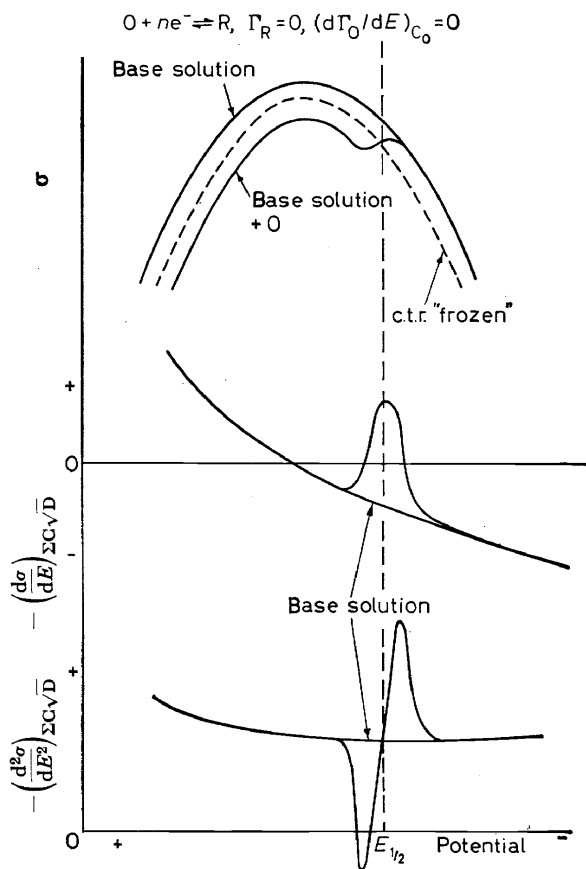

Figure 7. Influence of the adsorption of reactant O on the surface tension ( $\sigma$ ),

$$-\left(\frac{d\sigma}{dE}\right)_{\Sigma C\sqrt{D}} \quad \text{and} \quad -\left(\frac{d^2\sigma}{dE^2}\right)_{\Sigma C\sqrt{D}} \left(\Sigma C\sqrt{D} = C_R D_O^{\frac{1}{2}} + C_O D_R^{\frac{1}{2}}\right)$$

$(d\sigma/dE)_{\Sigma C\sqrt{D}}$  must be regarded only as an apparent double layer charge density, as it may include charge components connected with the reduction of O when R is adsorbed, and with the oxidation of R when O is adsorbed. The latter component is responsible for the hump seen on the  $(d\sigma/dE)_{\Sigma C\sqrt{D}}$  curve in Figure 7. At the half wave potential the apparent charge density greatly exceeds the corresponding charge density for the base solution. At this potential  $C_O$  is half the value at much more positive potentials and the real double layer charge density is the same as that for a solution containing half as much component O (we assume here that  $\gamma_0$  is a constant) when, by unspecified means, the electrode reaction is "frozen". Also, as we assumed earlier that  $(d\Gamma_O/dE)_{C_0} = 0$ , the real double layer charge density is at all potentials close to that for the base solution. Of the three potentials at which  $(d\sigma/dE)_{\Sigma C\sqrt{D}} = 0$ , only the most positive of the three really represents a point of zero charge.

### SPECIFIC ADSORPTION OF REACTANT— NO ELECTRODE REACTION

If the circuit in *Figure 6* is correct it should be possible to derive from it an equivalent circuit for the system when the electrode reaction does not take place but one of the reactants is present and is adsorbed at the interface. In this case  $R_{ct}$  is infinite and as only one of the two reactants is now present one of the transmission lines, the associated adsorption capacity and the associated current generator are removed from the circuit. We are left with the differential capacity  $C_{dl}$ , a current generator  $I(I)$ , an adsorption capacity  $C(I)$ , a voltage generator  $V(I)$  and the transmission line  $TL(I)$  where  $I$  may be O or R. The remnants of the original circuit present a peculiar appearance and although current flows through  $C(I)$  and  $TL(I)$  in the non-steady state this current does not flow in the external circuit. The only observed current is that supplied by the current generator  $I(I)$  which is, of course, linked to the current passing through  $C(I)$ . As  $V(I)$  is related to  $\Delta E$  by Eq. (18) and  $I(I)$  is similarly related to  $i(I)$  by Eq. (23) it is not difficult to see that the remains of the original circuit are equivalent to the circuit shown in *Figure 8(a)* where

$$\frac{C'(I)}{C(I)} = \frac{Z_{TL(I)}}{Z_{TL'(I)}} = \left[ \frac{RT}{nF} \left( \frac{d \ln \gamma_I}{dE} \right)_{C_I} \right]^2 \quad (24)$$

and  $Z_{TL} = (R_{TL}/C_{TL}\omega)^{\frac{1}{2}}$ . The final circuit is exactly that predicted by an earlier treatment of specific adsorption of a minor constituent<sup>14</sup>.

Such adsorption, from a thermodynamic viewpoint, can be treated as a charge transfer reaction involving the transfer of  $-RT/F(d \ln \gamma_I/dE)_{C_I}$  electrons to component I when it enters the interfacial region. Thus it should be possible to derive the circuit in *Figure 7(a)* by regarding the interfacial impedance as having a non-faradaic part ( $C_{dl}$ ) shunted by the faradaic impedance for this hypothetical charge transfer reaction. We may assume that the reaction leads to the formation of an entity  $I^\circ$  which is present at vanishingly small concentration in both phases but which is strongly adsorbed at the interface. Thus the faradaic part of the circuit (*Figure 8b*) consists of a transmission line  $TL(I)$  in series with an adsorption capacity  $C(I^\circ)$ . These components are defined by Eqs. (11), (12) and (16) and after substituting the value  $-RT/F(d \ln \gamma_{I^\circ}/dE)_{C_I}$  for  $n$  it is found that in all respects the circuit is identical with the one in *Figure 8(a)*. These tests confirm the accuracy of the present approach to the interfacial impedance and the latter test demonstrates clearly the difficulty of distinguishing experimentally between charge transfer to the interface as a whole and charge transfer to a particular component of the interface.

### METAL ION-AMALGAM REACTIONS

The circuit of *Figure 6* refers to an assumed model involving three distinct steps and it is pertinent to enquire to what systems may it be applied. It may be expected to be valid whenever one or both reactants are adsorbed in well defined forms at the interface. Thus one would expect it to describe well the impedance when O and R are organic species differing somewhat in structure

THEORY OF THE CURRENT IN A.C. POLAROGRAPHY

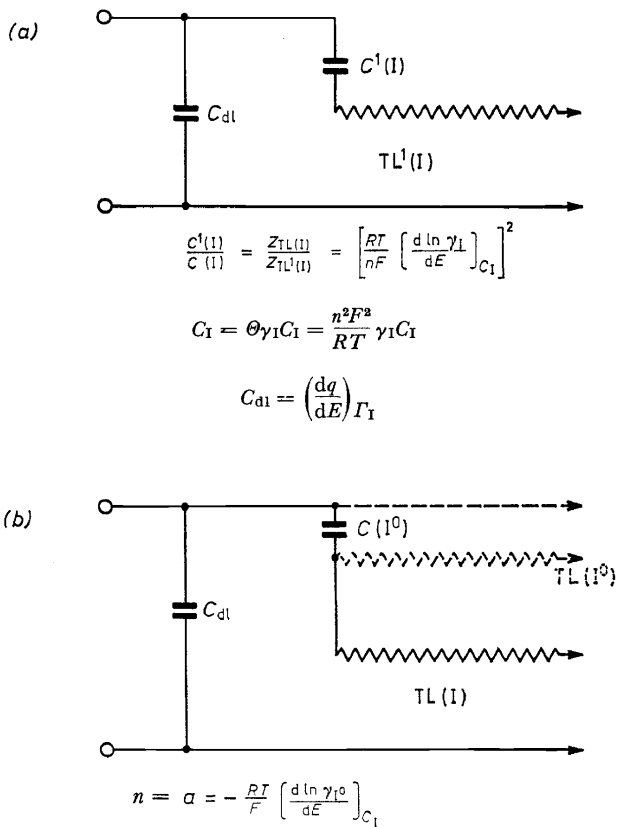

Figure 8. Circuit for the interfacial impedance when component I is adsorbed: (a) circuit derived from the circuit in Figure 6; (b) circuit when the adsorption process is treated as a charge transfer reaction,  $I + ac^- \rightleftharpoons I^0$  (ads)

or when O is a metal ion which is strongly adsorbed at the interface in the form of a complex ion or an undissociated molecule. It is possible, however, that for some metal ion-amalgam reactions the model should be somewhat more diffuse than this three step model. One might envisage adsorption in a variety of forms resulting in an average value for the apparent charge of an adsorbed metal ion less than its normal value and it is of academic interest to consider the form of the equivalent circuit when, following Lorenz<sup>11</sup>, the overall reaction is regarded as involving an infinite number of minute charge transfer steps. First, however, we consider the impedance for the two step sequence



If the earlier treatment of coupled charge transfer reactions is slightly extended it is found that the equivalent circuit for the faradaic impedance has the form shown in Figure 9(a). The transformer in this case is an auto-transformer so tapped that the voltage developed between the bases of TL(R)

and  $TL(OR)$  equals  $n_1/n$  times  $\Delta E$  and this transformer takes account of the fact that both reactions are simultaneously affected by the overpotential. Now we may assume that the entity  $OR$  is present only at the interface. Then the line  $TL(OR)$  is replaced by an adsorption capacity  $C(OR)$  and we now

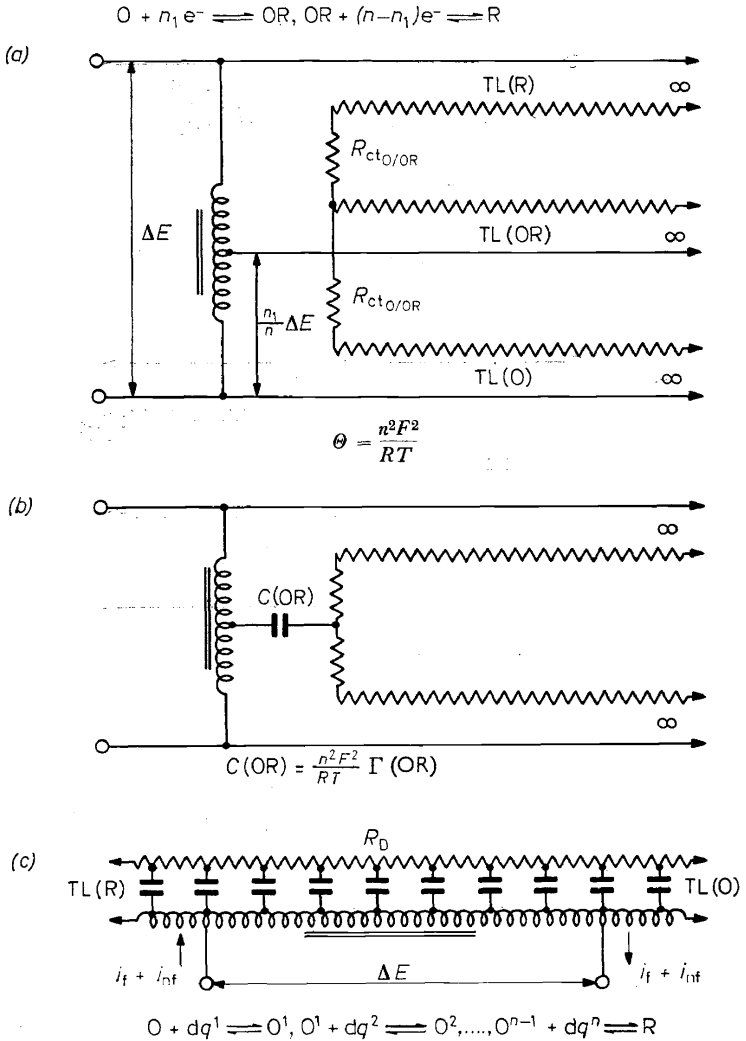

Figure 9. Circuits for metal ion–amalgam reactions: (a) two step charge transfer reaction; (b) circuit when the intermediate  $OR$  is only present at the interface; (c) circuit (schematic) for multi-step ion transfer.

have a circuit (Figure 9b) which not only takes account of the faradaic current but also non-faradaic current connected with the dependence of the double layer charge density on  $\Gamma_{OR}$ . The circuit for the entire interfacial impedance would be complete if we connected between the terminals of the

## THEORY OF THE CURRENT IN A.C. POLAROGRAPHY

transformer the differential capacity  $C_{dl}$  (for constant  $F_{OR}$ ). The circuit in *Figure 6* can also be arranged in a similar way†. By introducing an auto-transformer and connecting the adsorption capacities  $C(O)$  and  $C(R)$  to tapings on this transformer it is possible to eliminate voltage and current generators from the circuit, a change which some workers may welcome.

The circuit in *Figure 9(b)* shows how difficult it is to justify a division of the current into non-faradaic and faradaic parts as some of the "faradaic" current flowing through  $R_{ctOR/R}$  may flow through  $C(OR)$  and appear after transformation in the auto-transformer as a "non-faradaic" current passing between the input terminals of the transformer. Similar considerations apply to current flowing through  $R_{ctO/OR}$ . One further point should be mentioned. If the first step in this reaction sequence was in reality an adsorption step and  $n_1$  was negative in sign, the lower part of the autotransformer in *Figure 9(b)* would be extended downwards and  $C(OR)$  would be connected to a point below the lower of the two transformer terminals. Likewise, if  $n_1$  were to be larger than  $n$ , the adsorption capacity would be connected to a tapping above the upper of the two terminals.

From this discussion it readily follows that the equivalent circuit for a multi-step charge transfer process when a metal ion moves from a solution to the mercury phase takes the form shown in *Figure 9(c)* ( $C_{dl}$  has been again omitted for simplicity). The various capacities are related to the surface excesses of the ion at different planes in the interface and the various tapings on the transformer supply appropriate fractions of the overpotential at different planes. The resistance  $R_D$  replaces the charge transfer resistance or resistances of less general circuits and is to be regarded as a diffusion resistance connected with the diffusion of the ion in the interfacial region. No longer is it possible to clearly distinguish it from diffusion resistance in the region of the diffuse double layer or even from diffusion resistance ( $R_{TL}$ ) in the bulk of the phases.

## CONCLUSIONS

Thus we see that in principle it is not difficult to develop accurate equivalent electrical circuits for the interface when an electrode reaction takes place provided all chemical or electrochemical reactions are first order or pseudo first order reactions. Linear diffusion of reactants invariably is represented in the circuit by simple resistive transmission lines. Homogeneous chemical reactions lead to the presence of distributed resistance linking these lines and coupled charge transfer reactions can be allowed for with the aid of a transformer. Specific or non-specific adsorption of reactants can be allowed for with fair accuracy by additional capacities shunting the input terminals of the transmission lines. Strictly, however, voltage generators and current generators should also be introduced to allow for the direct dependence of the surface excesses on potential. Alternatively accurate allowance can be made for reactant adsorption by combining an autotransformer with one or more adsorption capacities and with lines associated solely with mass transport. It is also possible to construct an

† This change is permissible as the coefficients of  $\Delta E$  and  $i(I)$  in Eqs. (18) and (23) are identical.

equivalent circuit for the interfacial impedance when charge transfer is regarded as a multi-step process.

The aperiodic circuit may be quite complex in practice if several complications occur simultaneously. However it often happens that the circuit reduces to one of the forms shown in *Figure 10*. Thus the circuits in *Figures 2(b)*, *3(b)* and *4(b)* after combining the transmission lines take the form of the one in *Figure 10(a)* and as the faradaic part of this circuit is the electrical

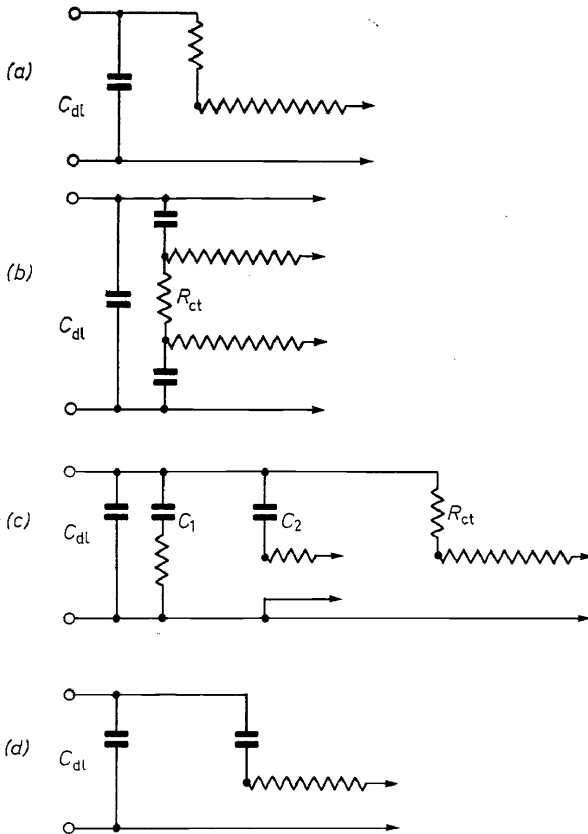

*Figure 10.* Basic forms of the equivalent circuit for the interfacial impedance.

analogue of heat conduction in a semi-infinite medium with radiation at the place  $x = 0$  it is possible, using known solutions of this problem, to write down immediately an expression for the faradaic current if the potential variation with time is sinusoidal, or if it can be broken up into potential steps appropriately spaced in time. If slight specific adsorption of reactants is combined with charge transfer irreversibility, the circuits may again reduce to the one in *Figure 10(a)*. If strong adsorption is combined with slight irreversibility and the circuit may be approximately identified with that in *Figure 10(b)*, it can be rearranged in the form shown in *Figure 10(c)*, and expressions for the currents flowing through the various vertical limbs of

## THEORY OF THE CURRENT IN A.C. POLAROGRAPHY

this circuit are usually not difficult to obtain. The combination of  $R_{ct}$  and a transmission line is the analogue of the heat conduction problem mentioned above. The combination of  $C_1$  and a resistance presents no problem and the series combination of  $C_2$  and a transmission line is the electrical analogue of heat conduction in a semi-infinite medium in contact with a well-stirred liquid at the plane  $x = 0$ , a diffusion problem solutions of which are known for various boundary conditions. These solutions also are of value when the circuit for the interfacial impedance takes the form in *Figure 10(d)* and, if the potential variation with time can be broken up into potential steps, an expression for the interfacial current is obtained almost immediately. There are, however, situations where the aperiodic circuit may be of little help in deriving an expression for the cell current, but it often is then the case that the system contains many unknown parameters and that an expression for the current is of limited practical value. Whatever methods may have to be used in the development of the theory of a.c. polarography and low level relaxation techniques, there clearly is always something to be gained by first considering the structure of the equivalent circuit for the interface.

*The author is indebted to Professor Paul Delahay for a pre-publication copy of a paper (with G. Susbielles) on the theory of the double layer impedance.*

### References

- <sup>1</sup> B. Breyer and F. Gutmann. *Trans. Faraday Soc.* **42**, 650 (1946).
- <sup>2</sup> E. Warburg. *Ann. Physik.* **67**, 493 (1899).
- <sup>3</sup> P. Dolin and B. Ershler. *Acta Physicochem. U.R.S.S.* **13**, 747 (1940).  
P. Dolin, B. Ershler and A. N. Frumkin. *Acta Physicochem. U.R.S.S.* **13**, 779 (1940).  
B. Ershler. *Disc. Faraday Soc.* **1**, 269 (1947).
- <sup>4</sup> J. E. B. Randles. *Disc. Faraday Soc.* **1**, 11 (1947).  
H. A. Laitinen and J. E. B. Randles. *Trans. Faraday Soc.* **51**, 54 (1955).
- <sup>5</sup> H. Gerischer. *Z. physik. Chem. (Frankfurt)* **198**, 286 (1951); **201**, 55 (1952).
- <sup>6</sup> K. J. Vetter. *Z. physik. Chem. (Frankfurt)* **199**, 300 (1952).
- <sup>7</sup> M. Senda and I. Tachi. *Bull. Chem. Soc. Japan* **28**, 632 (1955).
- <sup>8</sup> T. Berzins and P. Delahay. *Z. Electrochem.* **59**, 792 (1955).  
<sup>b</sup>P. Delahay, *Advances in Electrochemistry and Electrochemical Engineering*, Vol. **1**, Interscience, New York, 1961.
- <sup>9</sup> H. Matsuda. *Z. Electrochem.* **62**, 977 (1958).  
H. Matsuda. *J. Phys. Chem.* **64**, 339 (1960).
- <sup>10</sup> M. Senda and P. Delahay. *J. Phys. Chem.* **65**, 1580 (1961).
- <sup>11</sup> W. Lorenz and G. Salié. *Z. physik. Chem. (Leipzig)* **218**, 259 (1961).  
W. Lorenz. *Z. physik. Chem. (Leipzig)* **218**, 272 (1961).  
W. Lorenz and G. Salié. *Z. physik. Chem. (Frankfurt)* **29**, 390 (1961).
- <sup>12</sup> G. C. Barker in *Transactions of Symposium on Electrode Processes*, ed. E. Yeager, J. Wiley, New York (1961).
- <sup>13</sup> P. Delahay and G. Susbielles. *J. Phys. Chem.* **70**, 3150 (1966).
- <sup>14</sup> G. C. Barker and A. W. Gardner. *AERE-C/R* 1606 (1955).