

AUTOMATION OF ANALYTICAL PROCESSES

W. KOCH

Chemische Laboratorien der August Thyssen-Hütte AG, Duisburg-Hamborn, BRD

Automation of analytical processes becomes a necessity both in research and industrial laboratories whenever a large number of identical tests have to be carried out as rationally and reliably as possible. This task is relatively easy to accomplish when the choice of the method is left to the investigator; it is much more difficult when, for production control, individual results must be made available within a very short period of time which is dictated by the process pursued, in which case only such a method can be selected that meets with these requirements. It often happens that, for mere reasons of a rational use of expensive equipment, automated analyses are used for several parallel operations of a different degree of priority. This means that the different degrees of priority must be taken into consideration in the course of further operations. Such a problem, according to Kern¹, resembles that of a time schedule in railway stations, causing both additional difficulties in the set-up of such laboratories and the procurement of relevant equipment. In this paper, the term "rapid-analysis" is used for time-dependent tasks of production control as against merely automated performance of analyses.

Automated analyses and rapid analyses furnish such an amount of data within a relatively short period of time that the use of automatic analyzing equipment is in most cases also associated with the problem of collecting and processing the figures obtained. It is thus important that the results should be obtained in such a way as to enable them to be fed into a computer, *i.e.* they should either be directly stored or obtained in the form of punched cards or tapes.

While the *automated analysis* mostly offers the possibility of selecting a method that perfectly meets with the requirements of precision, today's *rapid analysis* often still involves the necessity of compromising and preferring, for instance, a more rapid, but less precise method to a more precise, but slower method. The latter process is then mostly used for checking and calibrating purposes.

The technical approach towards automation of analytical processes has now reached a stage where nearly any analytical method can be automated. The speed obtained then depends mostly upon the basic chemical reaction pursued or upon the physical or physicochemical action.

The most important step in automation is the conversion of values measured into electric analogue or digital readings. But, the methods used are not equally well suited for this purpose. An example of a process which is perfectly suited for this practice is given by *Figure 1* which shows the coulometric principle with potentiometric zero point detection. In this method, the current which generates or neutralizes (*i.e.* "titrates") ions in a solution

produces an immediate digital reading. In this case, individual pulses of a quantity of electricity can be adjusted electrically in such a way as to correspond exactly to a definite amount of an element, for instance, $1 \mu\text{g}$ carbon (1 ppm carbon) or $1 \mu\text{g}$ sulphur. For a given constant weight, the result is obtained immediately in digital reading percentage.

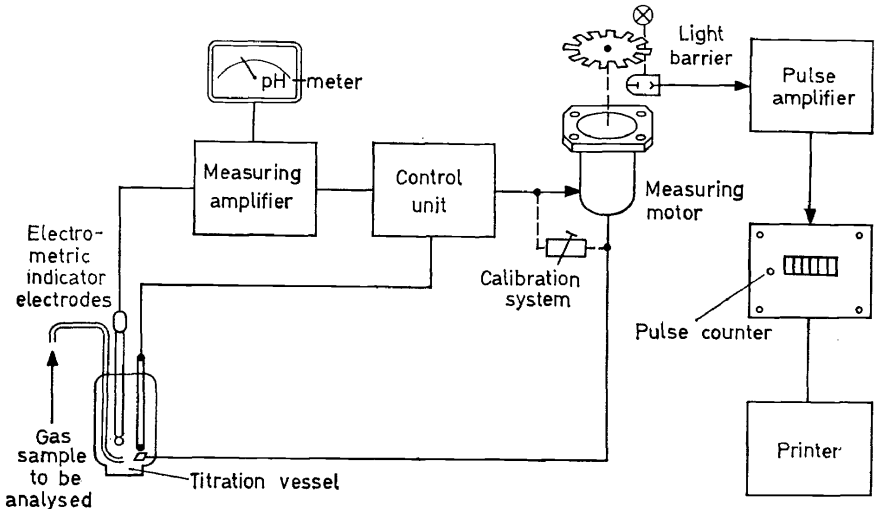

Figure 1. Principle of pulse coulometry

Within the limits of the error of electric measurements, such an automated coulometric method may be used as a calibrating method, for instance for the spectrometric determination of carbon, since according to the Faraday law the quantities of electricity exactly correspond to a certain amount of an element to be analysed. Coulometric methods may be used in many respects. In metallurgical analyses, they are now used to determine carbon, sulphur, oxygen, and nitrogen. The same elements may also be determined in organic substances. The pulses are readily stored magnetically or retained on punched cards or tapes.

In other analytical methods, for instance in photometric measurements and also in the determination of weight and volume, the value measured may also be obtained in the form of an electric analogue reading that in turn is relatively exactly converted into a digital reading. Perhaps the most important example here is the conversion of an already integrated electric value into a digital reading, for instance the voltage of a capacitor obtained in spectrometric analyses. Figure 2 shows a basic arrangement which permits a high accuracy (error $< 0.5\%$). Whenever the analogue reading is not linearly proportional to the concentration, such as may occur in spectrochemical analyses, for instance due to interelement effects and in higher concentrations, the result may still be digitalised by means of computers.

The principle shown Figure 3 demonstrates that this is also possible for analogue readings that have not yet been integrated, *i.e.* indicating the concentration of a substance for a certain period of time in a flow, *i.e.* a

signal which is obtained in flow photometry and in liquid and gas chromatographic determinations and also in the gas spectrometry and the tracer method in a flow counter tube, etc. Provided there is proportionality to the concentration at any time, the analytical readings may be divided into

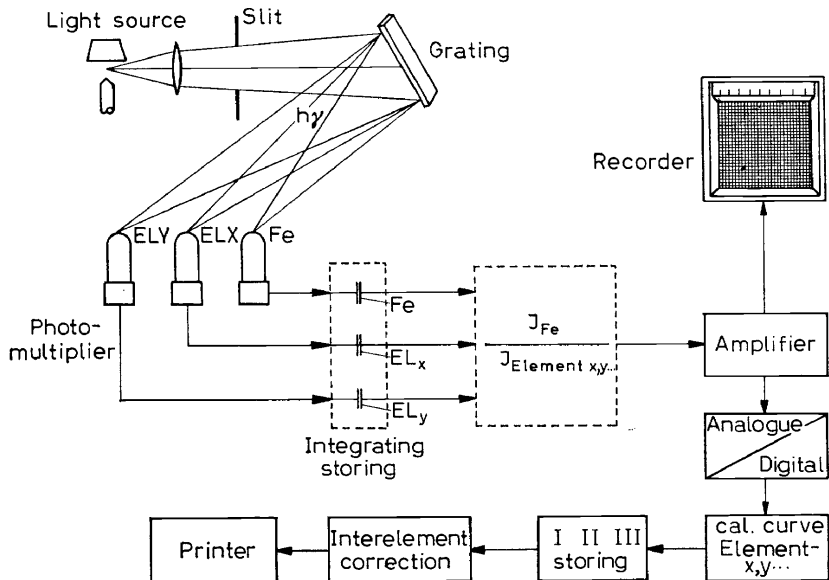

Figure 2. Conversion of integrated electric valve into digital reading

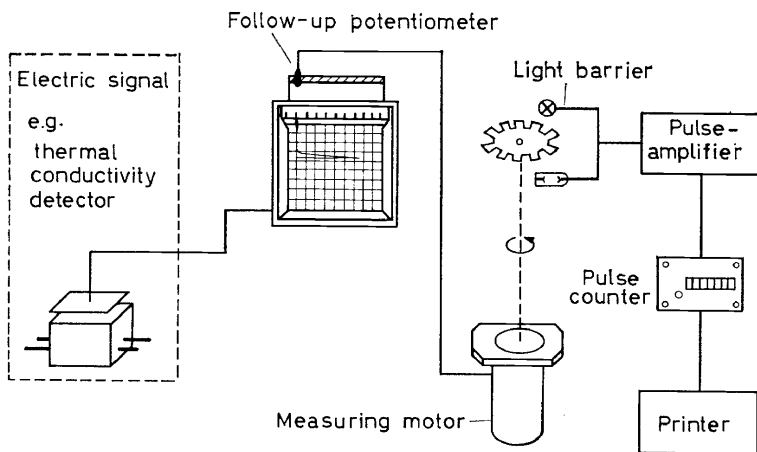

Figure 3. Conversion of non-integrated analogue signal into digital reading

pulses and converted into digital values of great accuracy by means of integration.

The difference between the methods shown in Figures 2 and 3 and the method of the coulometric-potentiometric principle is obvious: while the

pulses of the former require only slight electric adjustment, those of the latter always require a chemical calibration.

Analytical measuring techniques and human decision-making

The compilation of these technical steps into an automated process does not, however, cover all the problems to be decided by the analyst. He will have to find the approach to the measuring techniques to be applied and the human decision-making intervening in the operation, which may vary considerably from one task to another. He will have to consider (i) whether or not, and to what extent, automation of a given operation is required and useful, and (ii) if a decision has been made in favour of automation, to what extent and at what spot human decision-making must intervene in the process of automated analyses. With a view to clearly defining the aspects of technical approach to measuring techniques and human decision-making involved in the analyst's activities, some examples are given below.

A continuous CO₂ or CO measuring and recording device can be installed in a gas conduit to check the composition which varies within certain limits; and it can be expected to furnish a reliable value and cause a signal to indicate that the limits are being exceeded. The same refers to another device which continuously checks and adjusts the pH value of a solution. In both cases, human decision-making is of minor importance. As a rule, the entire operation requires no special human control.

Unlike the above operations, it is essentially a problem of human decision-making to determine the emission of an industrial plant or the emission at certain places. This is a problem of interpreting the measuring data by the analyst who, in addition, must be a first-class specialist of this line.

The analytical problems in research and production involve more or less aspects of human decision-making. In sampling, for instance, human decision-making often is of particular importance and yet forms an essential part of automation of analytic methods. Whenever the problem is to analyze a large amount of unhomogeneous material, such as a 50 000-ton load of ores, in order to determine the average content and the correct price, it will not be achieved by simply inserting (as in a gas conduit) a device into the bulk material and measuring the percentage of iron, metal, moisture, or oxygen. Here the question is how to take a representative sample from the entire stock. In deciding this point, human observation, special knowledge and experience always play an important part.

Even difficult sampling can be largely automated, as is shown in *Figure 4*. A bucket attached to a pivoting arm takes a partial sample at calculated intervals from the material flow arriving from the left. These partial samples are fed through a collecting bin onto a screen where the coarse percentage is derived to a crusher. Both portions are brought together onto a slowly rotating disc where a definite percentage drops through slots into the sample collecting bin, while the rest is wiped off onto a conveyor belt which returns it to the discharge flow.

Subsequent to a preliminary inspection and evaluation of the grain structure, etc., the specialist statistically calculates the number and scope of partial steps required for such an equipment. It is not until these material-

AUTOMATION OF ANALYTICAL PROCESSES

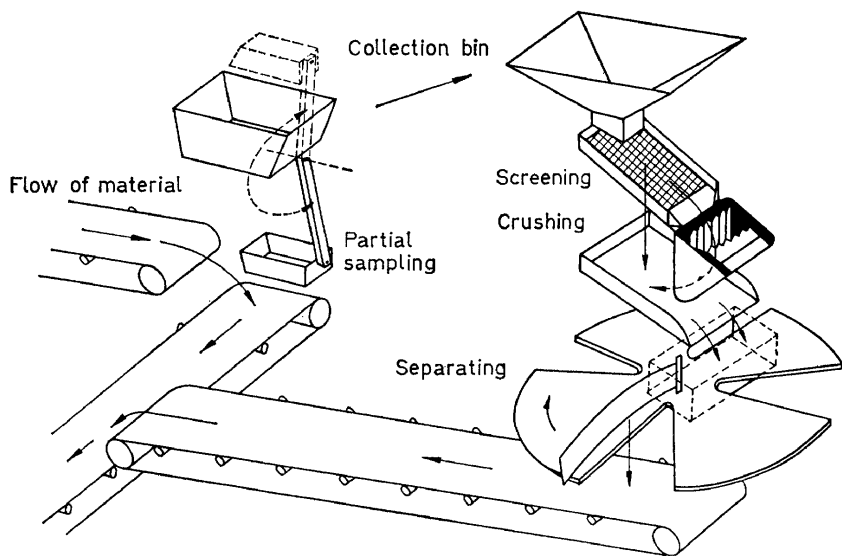

Figure 4. Automatic ore sampling

dependent steps have been established that such installations succeed—during loading of large amounts of varying and rather heterogeneous material—in automatically taking samples of a composition that varies by less than a few tenths of a per cent. *Figure 5* shows some test results which characterize the mode of operation of such an automatic installation.

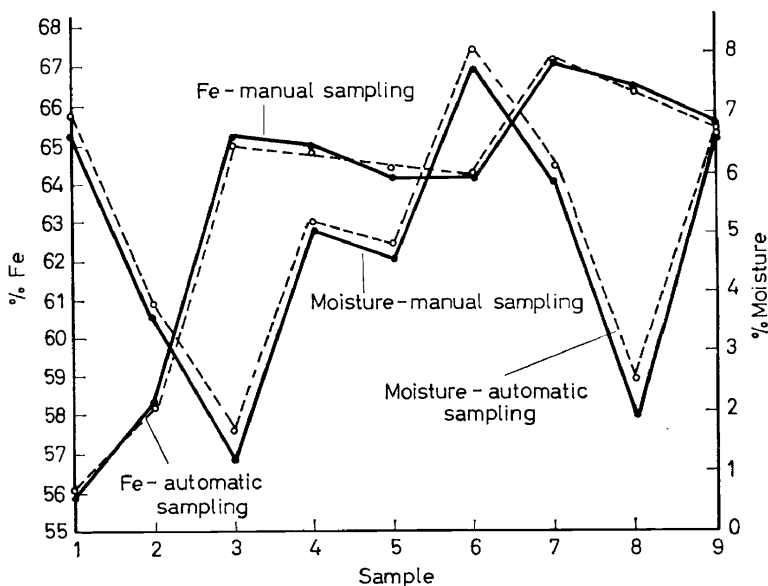

Figure 5. Comparison of automatic and manual sampling

For comparison, the results of manual sampling are also shown. The percentage of iron reveals positive and negative deviations. This obviously is the normal scatter of the method. For moisture, however, systematic deviations can be observed. These deviations are caused by the loss of moisture occurring as a result of longer handling during manual sampling.

Similar difficulties must be overcome when taking samples of liquid metals from melting furnaces. Knowledge of the characteristic features of the melting process and conditions of solidification of the sample are a prerequisite for good results. It is only through strict observation of the sampling conditions established subsequent to prolonged studies that representative samples can be obtained for the entire heat in which often 10–15 elements of different segregation have to be analyzed. In spite of the established sampling conditions, the grade of each individual sample still requires human inspection with respect to its property and some alloying additions which increase its homogeneity.

The question of human decision-making intervening in the process of investigations in a central high-speed laboratory, such as it exists nowadays in any larger steel mill, should be briefly outlined here. Such a laboratory serving several production units consists of a department for sample preparation and another for sample investigation.

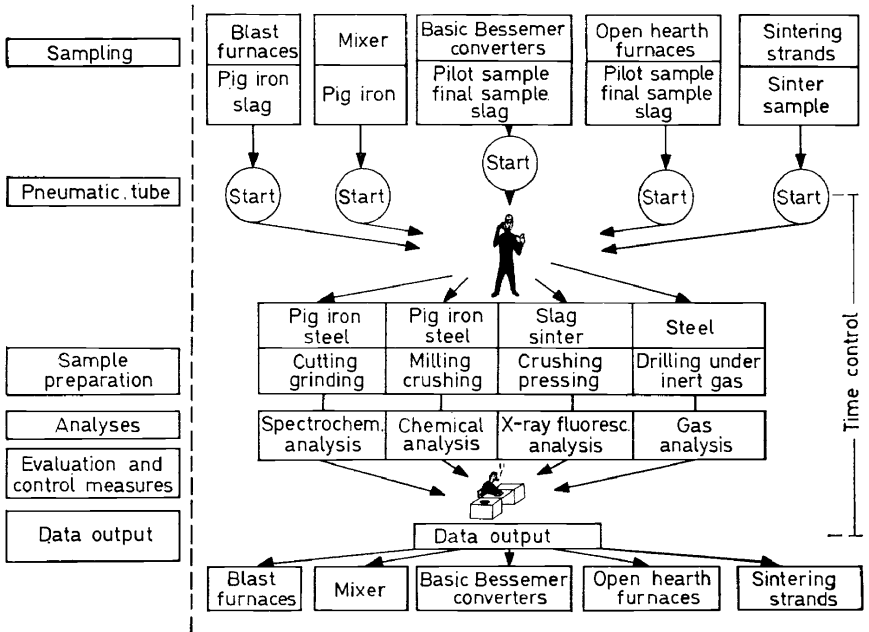

Figure 6. Scheme of sample preparation laboratory

First, Figure 6 shows in a diagram the operations of the department for sample preparation where samples are being received from several melting shops at certain intervals. A pneumatic tube system exists between these shops and the laboratory. Not only must the incoming materials be quickly

prepared, but also their priority has to be observed. Therefore, the investigating man must be fully familiar with the operations of each shop and keep in close touch with the shop and the analytical department.

In these laboratories for sample preparation, the samples are being prepared from the raw stock for different automatic devices. The spectrometer essentially requires a ground surface; the electrochemical and the chemical methods need chippings, the same as the gas analysis; samples for the oxygen determination must, in addition, be prepared in such a way as to prevent the adsorption of oxygen.

Figure 7 now gives a general idea of the actual, widely automated process of analyzing.

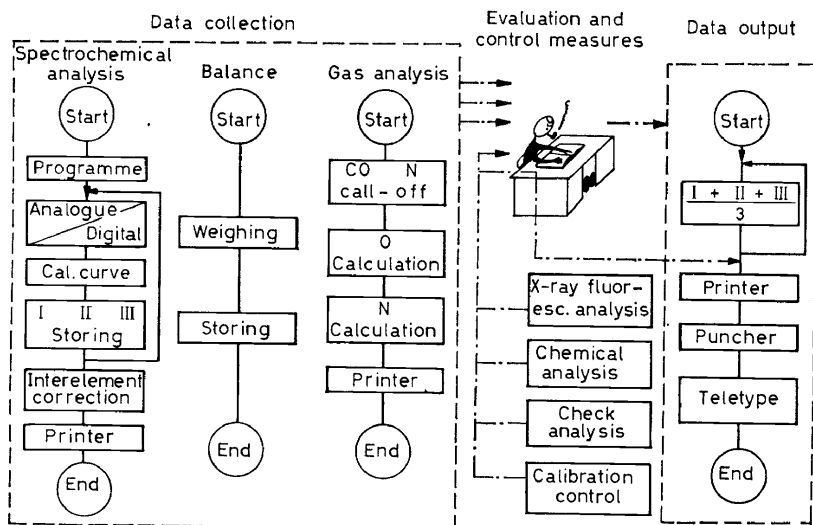

Figure 7. Scheme of automatic analysis cycle

It is an inherent feature of analytical investigations that several measurements are made to obtain a reliable result and that a mean value is determined using further controls established sometimes by other methods in order to obtain a result as accurate as possible. The same happens when automatic analyzers are used. In this respect, this picture first shows as an example an emission spectrometer (not an x-ray fluorescence apparatus). Large-size laboratories use several of these devices simultaneously. According to the principle discussed earlier in Figure 4, the intensity ratios of analytical spectral lines to an inner standard, *i.e.* for instance the ratio of intensity of a manganese line to another more intensive line, are being stored in the form of a capacitor voltage in the spectrometers for a larger number of elements. These values are first converted into digital values by means of a computer; then they are subjected to programmed interelement corrections and finally printed. It is in this form that the parallel results appear before the analyst who has to make his decisions now. He has to find out (i) whether the analysis variations of the different values determined by parallel actions are within the usual limits; (ii) whether the values measured are in accordance with the

production desired or whether, in cases of decision-making, they must be subject to an especially exact control (analytical decision-making within the quality limits); (iii) whether he must—on his own initiative and for time-saving reasons—direct new sampling or controls to be made immediately upon receipt of the first values measured. His decision will be easier to make if he receives values of the same heat analyzed by means of different equipment, for instance those of the pertinent slags (x-ray fluorescence); (iv) whether he must order immediate calibration controls for checking the equipment and the reference samples. He will do so whenever his particular experience and knowledge tells him that this is necessary.

It will then be his responsibility—after consulting all documentation—to decide whether a mean value is formed or a correction (red) is to be made in the result to be issued.

The example given here includes another type of apparatus for the automatic determination of oxygen and nitrogen which does not yet form part of standard equipment. Since such an apparatus was developed by our laboratory, I would like to avail myself of this example in order to enlarge a little more on the problems of automation of analytical methods. In the first place, *Figure 8* demonstrates the basic scheme of this automatic device. It

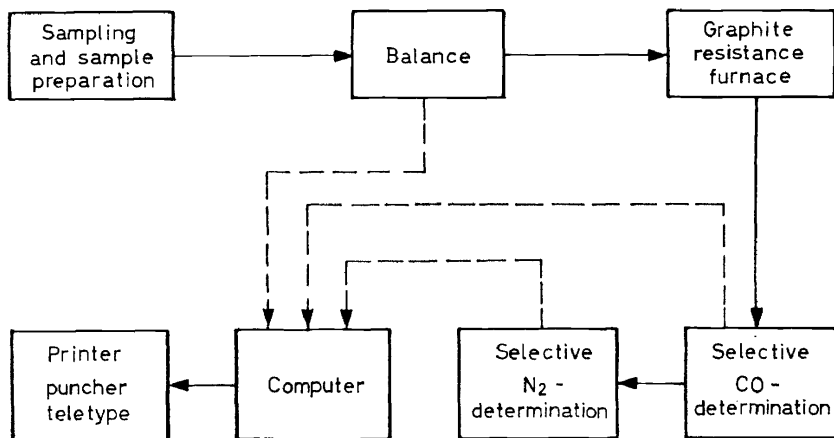

Figure 8. Scheme of an automatic equipment for determining nitrogen and oxygen

had then to be developed step by step in such a way as to enable the oxygen and nitrogen determinations to be performed as rapidly in the preliminary test laboratory as the spectrometrical determination of the other elements.

The basic feature of the method is that a steel specimen is melted under helium in a graphite crucible, with the oxygen being set free in the form of carbon monoxide and nitrogen in elemental form which are then determined in the helium carrier gas flow sweeping across the melt. As in any other analytical method, difficulties start to turn up as soon as the samples are taken and the specimens are prepared. Here the problem was to find out whether and to what extent reproducible raw samples could be taken from a steel melt. These investigations of world-wide interest which were completed in a joint venture within the framework of the International Committee,

led to the conclusion that so far an immersion mould with aluminium deoxidation provided the best starting material for the above investigation, though even here relatively large variations of the oxygen distribution were still to be expected in this starting material.

When entire test specimens are taken from such a starting sample for the purpose of analyzing them, relatively large variations are still observed (*Figure 9, left*). But, when taking drillings from the starting sample which may be mixed, the variations are considerably reduced as can be seen from *Figure 9, right*. Nevertheless, except for a few cases, the sampling error remains more considerable than the analytical error.

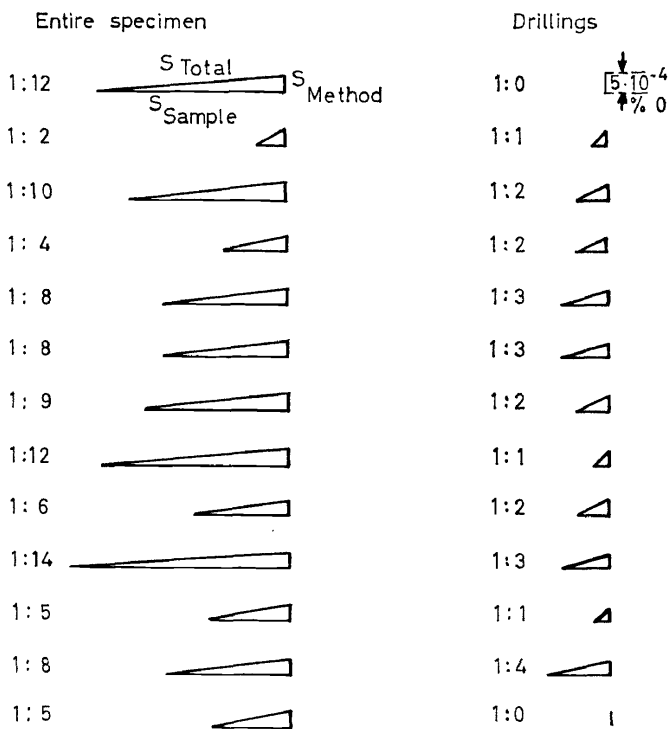

Figure 9. Oxygen determination: comparative investigations

However, since drillings tend to oxidize in contact with the atmosphere, a device had to be developed which allowed drilling to be performed under inert gas.

Figure 10 shows the device in which the sample (7) is drilled in a small air-tight drilling chamber (6). The drillings are placed into a cooled copper vessel (5). The time required for this operation is about 1 min.

In the beginning, the combined rapid determination of oxygen and nitrogen encountered unsurmountable difficulties. It was observed that when melting steel containing aluminium oxide, carbon monoxide was set free too slowly. Besides, nitrogen was not set free quantitatively. Figure 11 demonstrates how these difficulties were overcome.

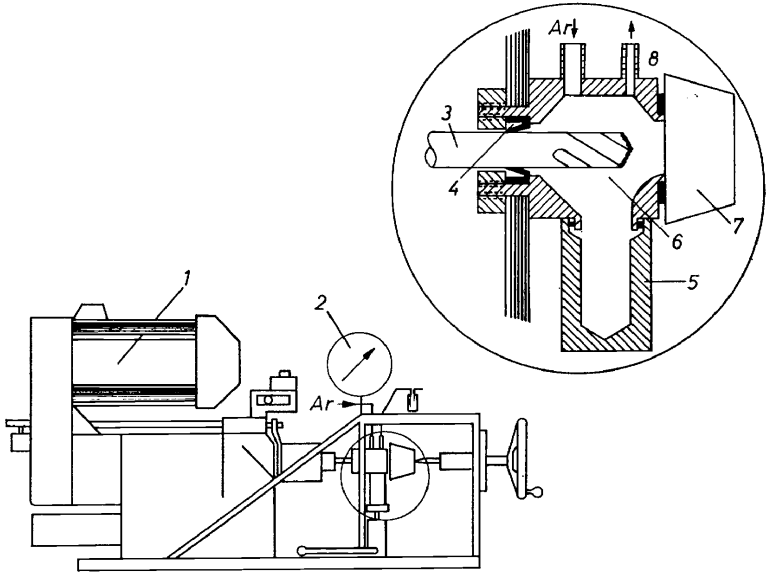

Figure 10. Device for making drillings under argon (1, Hydraulic horizontal drilling machine; 2, Pressure gauge; 3, Drilling bit; 4, Shaft gasket; 5, Copper vessel; 6, Drilling chamber; 7, Sample; 8, Lead sealing)

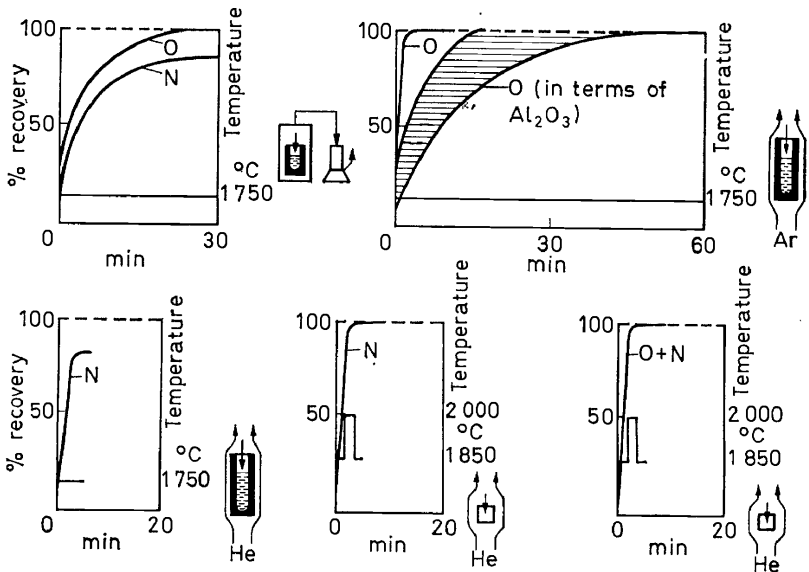

Figure 11. Effect of temperature control, crucible size and charge on the evolution of gas

In the previous vacuum fusion technique the samples were placed in a big crucible with a metal bath, and the extracted gases were removed from the furnace by means of vacuum pumps, collected and then analyzed. For most of the samples, the extraction of carbon monoxide was quantitative, requiring about 20–30 min. The nitrogen determination could not be used due to the incomplete extraction of nitrogen from the melt.

The oxygen determination was further developed and resulted in the present carrier gas technique. Here, too, the samples were placed in a large crucible with a metal bath, and the extracted gases were flushed from the furnace, using argon; carbon monoxide was oxidized into carbon dioxide using the Schütze-type reagent; and carbon dioxide was titrated automatically by the coulometric method. The time required for analyzing steels with no aluminium oxide was reduced to approximately 2 min; for steels containing aluminium oxide, however, it took about 20–60 min.

In the meantime, the extraction of nitrogen was performed quantitatively. The use of the carrier gas method and further improvements of the design permitted the nitrogen extracted from the melt to be collected and analyzed more rapidly. Nevertheless, as before, all of the nitrogen could not be determined in the large crucible with a metal bath.

Since calculations² indicated that nitrogen could be expected to evolve quantitatively from the melt, the processes occurring during extraction were studied thoroughly. It was established that the extraction of nitrogen in the metal bath was impaired by carbon deposits^{3–5} and that improved results could be expected when a new smaller graphite crucible would be used for each sample to be analyzed³. The extraction is then quantitative, as can be seen from the bottom curve in its central part. With a view to prolonging the time prior to the evolution of carbon and thus increasing the safety margin for a quantitative extraction, the temperature of the melt was increased automatically by 100–150° at the end of 10 sec. This increases the carbon absorbing capacity of the melt and the time elapsed prior to its saturation. The extraction is now quantitative in less than 2 min.

Based on these findings, a nitrogen carrier gas device was first developed that has been replacing our laboratory's wet chemical methods of nitrogen determination for the past two years. It is being used in three shifts.

For a combined determination of oxygen and nitrogen, ways and means had still to be found to reduce aluminium oxide-bearing steels as rapidly as those with no aluminium oxide. Another technique developed by us for the determination of oxygen in oxides⁶ had revealed that corundum—regardless of its fabrication, and embedded in graphite nodules—is rapidly and quantitatively reduced at 1900°, even with a grain size up to 70 μ . It should therefore also be possible to apply this method to steel samples containing aluminium oxides. The question was to find out whether for CO, too, the carbon content of the metal bath would not impair the degassing process and whether it is not at all a delayed reduction of the aluminium oxide. Thus, the furnace designed with the new smaller graphite crucible was built into the oxygen carrier gas device. The process of extraction resulting from this application was indeed identical in time with that of the nitrogen determination and the reduction of steels with no aluminium oxides (*Figure 11*, right bottom hand).

Figure 12 shows a series of oxygen and nitrogen chromatograms obtained, on the one hand, by placing successively in one crucible samples equal in weight and, on the other hand, by placing each sample in a new crucible without any metal bath. The disadvantage of using a big crucible with a metal bath is evident.

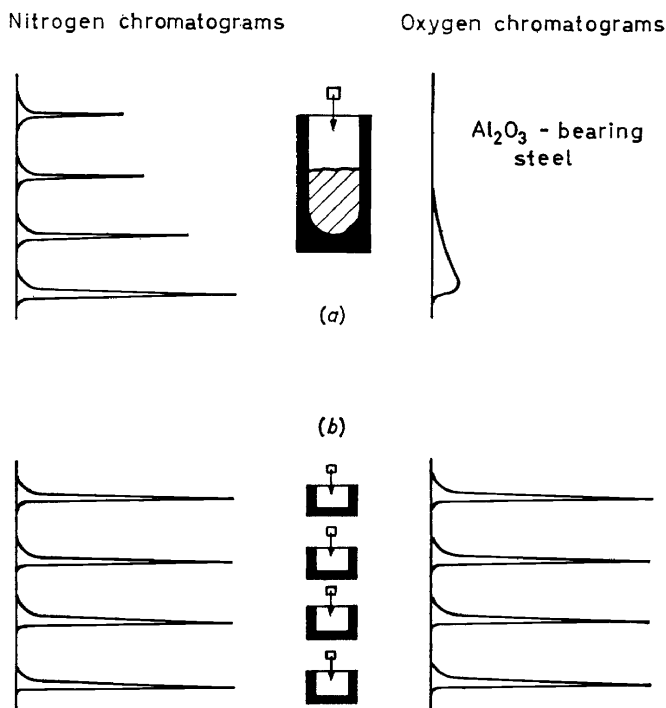

Figure 12. Degassing curves: (a) Large crucible with metal bath; (b) Small crucible without metal bath

So far, no mention has been made of the difficulties encountered in designing a device which uses a new crucible for each bath. In order to reduce the time required for analyzing, it was necessary to keep the furnace space very small. The design adopted is shown in Figure 13. The crucible (5) is placed on top of an elevator (3), removed through the bottom of the furnace upon completion of the analysis, and replaced by another crucible which in turn is again introduced into the furnace. This operation is automatic and takes 45 sec. Heating is done the indirect way by means of the graphite heating element (4) enclosed in a steel cooling jacket (6).

When melting a steel sample in a graphite crucible, such gases as hydrogen, carbon monoxide, and nitrogen are set free. Using a flow of helium carrier gas, they are flushed from the furnace and are directly measured. Since carbon monoxide possesses an electric dipole moment, it can be determined by way of infrared absorption. Thermal conductivity measurement appeared to be a means of determining nitrogen due to the considerable difference in

thermal conductivity between helium and nitrogen. When including the furnace in the flow of the infrared and gas chromatographic instruments, it is necessary for a rapid analysis that—subsequent to replacing the crucible and inserting the sample which requires the instrument to be opened for a

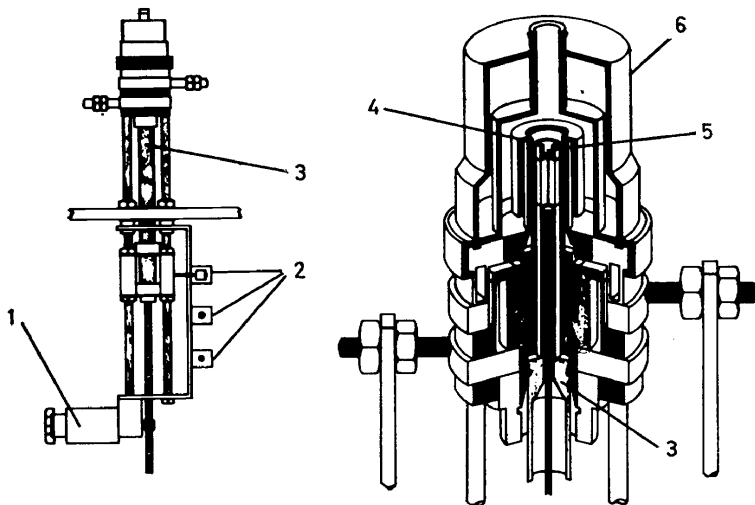

Figure 13. Furnace design and replacing of crucible (1, Motor for crucible elevator; 2, Controlling contacts; 3, Crucible elevator; 4, Heating element; 5, Graphite crucible; 6, Cooling jacket)

brief moment—a rapid base line fitting be achieved, *i.e.* that no foreign gas be admitted into the system during this operation. In addition, it is necessary for the crucible to be degassed prior to starting the analysis and quickly to remove the degassing products from the furnace.

Figure 14 shows how these problems have been solved. The main feature of this automatic analyzer is its particular gas flow. When analyzing a sample, the sample gas flow passes through the furnace (7), the dust filter (9), the infrared unit (11), the oxidation and separation columns (12), and the thermal conductivity measuring cell (14). The reference path of the measuring cell is constantly flushed with helium. This purging gas flow and the replacement gas flow are shut off by a magnetic valve (13). Once the analysis is completed, the crucible is removed from the furnace by means of the crucible elevator (16). At the same time, the magnetic valve is switched in such a way as to allow the sample gas flow and the purging gas which now flows in the inverse direction through the columns, the infrared unit, and the furnace, to escape underneath the furnace. After replacing the crucible and retracting the elevator into the furnace, the sample port (8) is opened, and the preheating products of the crucible escape into the open air. This system of gas flow prevents foreign gases from entering the furnace when replacing the crucible, thus permitting an analysis to be made every $3\frac{1}{2}$ min. During this period, a replacement gas flow passes through the measuring cell in order to maintain the temperature. A compensation

recorder (15) and an integrator (16) are connected to both the infrared unit and the thermal conductivity measuring cell. For the time being, the former automatic device is still operating without a computer (17), but using constant weighing. For calibration, pure gases are introduced into the carrier gas flow by means of calibrating valves (4).

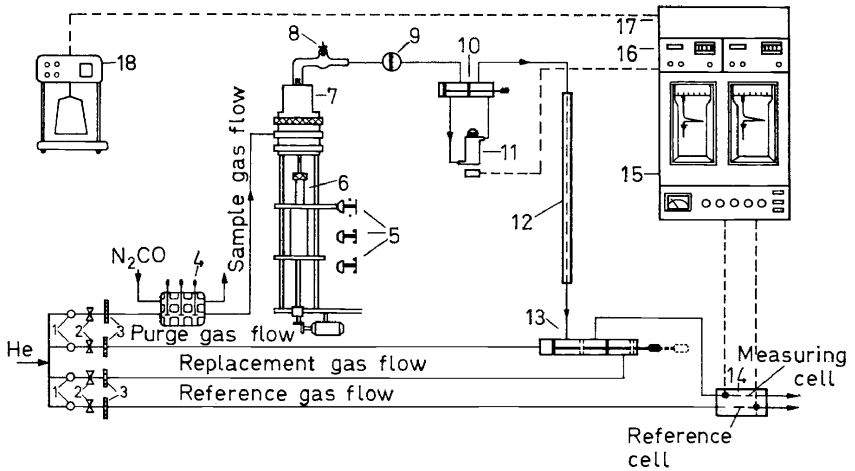

Figure 14. Scheme of instrument for combined determination of nitrogen and oxygen (1 Constant pressure regulator; 2, Precision regulating valve; 3, Flow meter; 4, Calibrating valve; 5, Limit switch; 6, Crucible elevator; 7, Graphite resistance furnace; 8, Sample port; 9, Dust filter; 10, Valve; 11, Cell; 12, Separation column; 13, Magnetic valve; 14, Thermal conductivity detector; 15, Recorder; 16, Integrator; 17, Computer; 18, Balance

By properly setting the valve (10), nitrogen and oxygen may be determined either separately or jointly.

To check the reproducibility of the results obtained with these automatic analyzers, steel samples containing various concentrations of oxygen and nitrogen were analyzed 15 times. Also various amounts of calibrating gas were introduced into the instrument. Figure 15 shows the variation coefficients calculated from these operations. This result shows that, besides a high speed, an extraordinarily high accuracy and sensibility were also obtained.

The variation coefficient is plotted against the axis of ordinates, the concentration of per cent oxygen or per cent nitrogen is plotted against the x-axis. For the oxygen determination using a 10 mm cell it can be seen that from 0.02 per cent oxygen on the variation coefficient in test gas analyses (referred to 0.5 g sample weight) is smaller than 1 per cent.

In the analysis of steel samples it is approximately 3 per cent for a range of 0.015 to 0.100 per cent oxygen. An increase of the variation coefficient for the range below 0.015 per cent oxygen may be reduced, as can be seen in the diagram, by means of a larger cell.

For nitrogen determinations there is hardly any difference between the results obtained in test gas and steel analysis. From 0.002 per cent nitrogen on the variation coefficient is 2.5 to 1 per cent. The distance between the curves is an indication of the scatter of the test material which is much

AUTOMATION OF ANALYTICAL PROCESSES

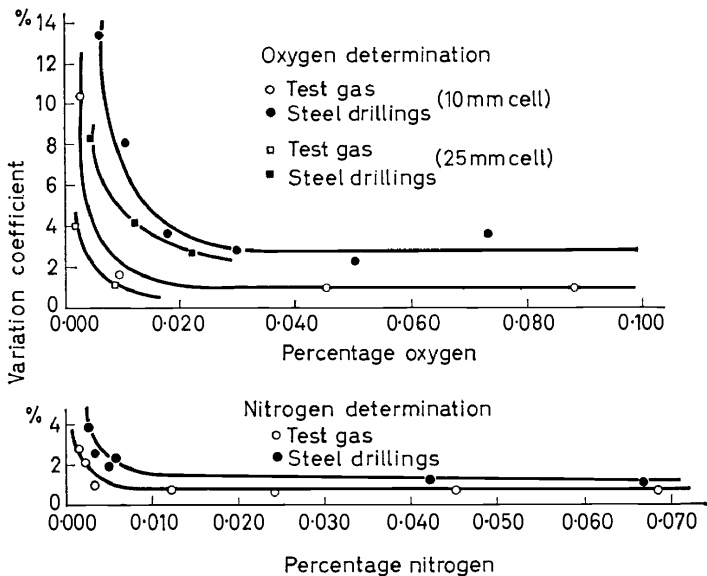

Figure 15. Variation coefficient as a function of content

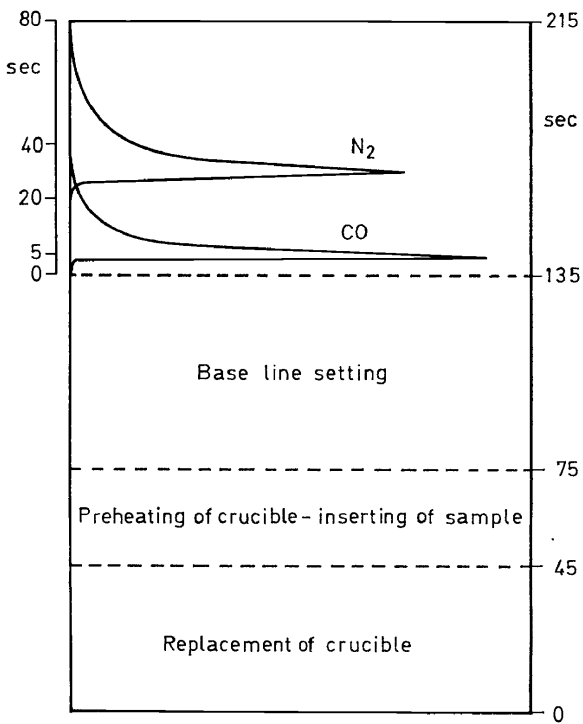

Figure 16. Time required for combined determination of nitrogen and oxygen

smaller for the nitrogen determination than for that of oxygen. The sensitivity for determining nitrogen is better than 0.1 ppm.

The chronological sequence of the analysis is shown in *Figure 16*. It is only 5 sec after inserting the steel sample into the crucible that the integrating measurement of carbon monoxide begins; 40 sec are required to complete the extraction and the measurement. After a period of 25 sec, the second recorder starts the nitrogen measurement which is completed within 80 sec. The 80 sec required for completing the extraction and the measurement of carbon monoxide and nitrogen cannot be considered, however, as being the total time taken for the analysis. The total time is that required for replacing the crucible, preheating the crucible, base line fitting, and analyzing. All these operations together take about $3\frac{1}{2}$ min.

From the total of 215 sec required for serial analysis, 75 sec may be subtracted for production analysis since the operations of replacing and preheating the crucible are mostly accomplished when the sample arrives in the laboratory by way of the pneumatic system, thus leaving no more than 140 sec required for the completion of the analysis.

References

- ¹ H. Kern. *Arch. Eisenhüttenwesen*, in the press.
- ² H. A. Slowman, C. H. Harvey and O. Kubaschewski. *J. Inst. Metals* **32**, 391 (1951).
- ³ H. Lemm. *Z. analyt. Chem.* **209**, 114 (1965).
- ⁴ A. Gerhardt, Th. Kraus and M. G. Froberg. Dissertation presented by A. Gerhardt to Fakultät für Bergbau und Hüttenwesen der Technischen Universität Berlin. Herausgegeben von der Balzers AG, Lichtenstein.
- ⁵ W. Koch and H. Lemm. *Z. analyt. Chem.* **215**, 377 (1966).
- ⁶ W. Koch and H. Lemm. *Arch. Eisenhüttenwesen*, in the press.