

MULTIPLE RESONANCE TECHNIQUES IN THE STUDY OF THE MAGNETIC, RADIATIVE AND NON-RADIATIVE PROPERTIES OF THE TRIPLET STATE

M. A. EL-SAYED†

Chemistry Department‡, University of California, Los Angeles, California

ABSTRACT

A physical picture of the origin of the zero field splittings and levels of the three zero field spin states of aromatic molecules is given. At very low temperatures ($< 2^\circ\text{K}$), the spin-lattice relaxation processes between these levels can be frozen. Under these conditions, the emission properties of the lowest triplet state are the sum, rather than the population-weighted average, of those of the different emitting zero field levels. Since the rates of pumping and deactivating the different zero field levels of the lowest triplet states are most likely to be unequal, the steady-state population of these three levels becomes unequal, i.e. a state of spin alignment in one molecular direction can be produced. A number of phosphorescence-microwave multiple resonance experiments can thus be carried out from which the following information can be determined: (1) the zero field origin of each vibronic band in the phosphorescence spectrum; (2) the relative rates of the non-radiative intersystem crossing process to the individual zero field levels of the lowest triplet state (and thus the mechanism of the intersystem crossing process); (3) the magnetic energies required to change the electron spin as well as the nuclear spin directions in the molecular framework in the absence of a laboratory magnetic field (but in the field of the two unpaired electrons in the lowest triplet state); and (4) spin-direction selection rules in the intermolecular triplet-triplet energy transfer process. The possibility of controlling the rate of a photochemical reaction involving the triplet state by saturating the zero field transitions with microwave radiation is briefly discussed.

INTRODUCTION

During the past few years, new observations were made on the properties of the lowest triplet state (T_1) at very low temperatures. The phosphorescence decay becomes non-exponential^{1,2}, and the emission can sometimes change polarization during its decay³; e.s.r. emission, instead of absorption, is observed⁴, and great changes are observed in the relative intensity (and sometimes the polarization) of the different bands in the phosphorescence spectrum⁵. At these temperatures, the decay^{1,2} and (for some molecules) the relative intensity of the different bands in the spectrum become sensitive

† Alfred P. Sloan Fellow.

‡ Contribution No. 2657.

to the application of magnetic fields^{1,2,5} as well as to microwave radiation of resonance frequencies^{6,7}. All these observations can be understood if at these temperatures the spin-lattice relaxation processes between the zero field (z.f.) levels of the triplet state become slow compared to the radiative processes. If thermal equilibrium between the three z.f. levels is not established and if the intersystem crossing processes (the non-radiative $S_1 \rightsquigarrow T_1$ or the $T_1 \rightsquigarrow S_0$ radiative or non-radiative processes) differ for the different z.f. levels of T_1 , it is very possible to produce T_1 in a state in which the steady-state population of the different z.f. levels is not equal.

PHYSICAL PICTURE OF THE ORIGIN OF THE ZERO FIELD SPLITTINGS IN AROMATIC MOLECULES

Let us discuss the triplet state of an atom in an electronic state with an electronic motion and thus distribution that is independent of the spatial direction around the nucleus, e.g. the electronic distribution in an 3S state. In the absence of a magnetic field, one may select three perpendicular planes (e.g. MN , LN and ML) and quantize the spin motion of the two unpaired electrons in these planes so that the component of the spin angular momentum in the direction perpendicular to the plane chosen is zero. If the two electrons are spinning in the ML plane, the components of the spin angular momentum along N is zero, and the z.f. level is to be called the τ_N level. Similarly, the τ_M and τ_L z.f. levels correspond to the magnetic states of the triplet state in which the two unpaired electrons are spinning in the NL and MN planes, respectively, with a zero component of spin angular momentum along the M and L axes, respectively. It is obvious that for the 3S state of an atom in zero field, the average distance of the two parallel spins in the three different planes is the same. The repulsive magnetic dipolar interaction between the two similar magnetic dipoles of the two unpaired electrons is thus independent of the plane in which the two electrons select to spin. Thus τ_N , τ_M and τ_L in *Figure 1* all have the same energy. If a magnetic field is applied along one of these directions, the Zeeman energy will be different when the electrons are in the three different planes, resulting in the splitting of the z.f. degeneracy of the 3S of the atom.

Instead of applying a magnetic field to change the energy of the different z.f. levels of the atom [by adding a new magnetic (Zeeman) interaction that is anisotropic], let us perturb the electronic distribution of the two unpaired electrons so that the average distance between them in the different planes selected above becomes unequal. This would make the dipolar magnetic interaction between the two unpaired electrons anisotropic. As shown in *Figure 1*, this can be accomplished in two steps. If one would flatten the electronic distribution along N , one would change the electronic distribution from spherical to a disc-like distribution. The electronic distribution found for the π -system in benzene, where N is the normal axis to the molecular plane, is almost a disc-like distribution. It is obvious that the average distance between the two unpaired electrons giving rise to this electronic distribution is larger in the ML plane than in the other two planes. Furthermore, the average distance between the two unpaired electrons in the NL plane is equal to that in the MN plane. Realizing that the interaction between two parallel dipoles

MULTIPLE RESONANCE TECHNIQUES AND THE TRIPLET STATE

is repulsive, one would expect that the τ_N level would be stabilized, whereas the τ_L and τ_M levels would be destabilized by equal amounts as compared to the original corresponding levels for the atom. Thus in benzene, two of the z.f. levels are degenerate and the third one is lower in energy than the doubly degenerate z.f. level.

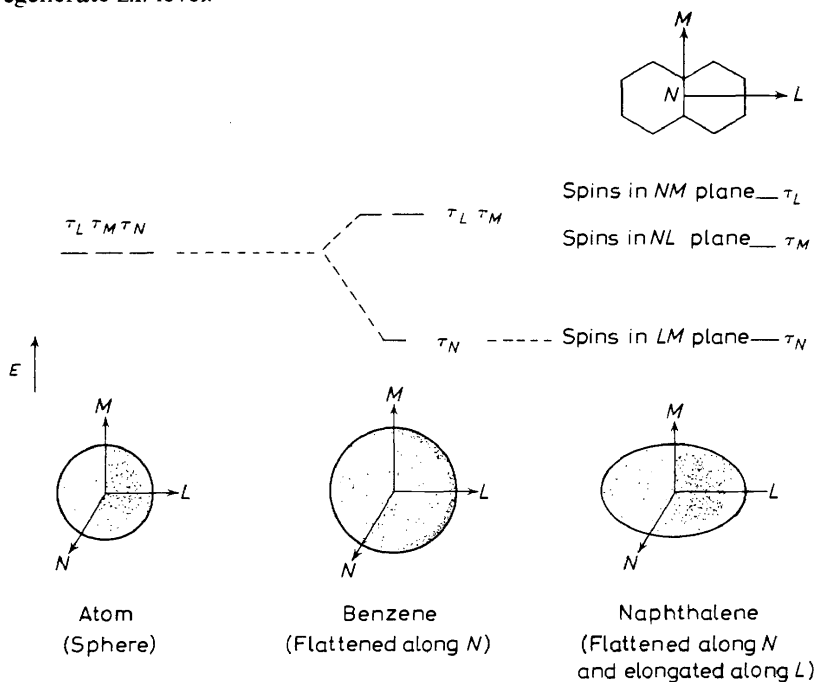

Figure 1. The origin of z.f. splitting in the triplet state of aromatic molecules. Since the electronic distribution in these molecules is not spherical, the average distance, and thus magnetic dipolar interactions, will depend on the plane in which the two electron spins are placed.

Suppose we elongate the electronic distribution of the two unpaired electrons along L in addition to flattening it along N . One gets a distribution similar to that present in the π -system of linear catacondensed aromatic molecules, e.g. naphthalene, anthracene, tetracene, etc. In these molecules, the average distance between the two unpaired electrons in the MN plane is no longer equal to that in the NL plane. The average distance in the MN plane is smaller than that in the NL plane, thus raising (destabilizing) the τ_L level and lowering (stabilizing) the τ_M level relative to the doubly degenerate level found in the non-elongated distribution.

The three z.f. triplet levels of the triplet state of aromatic molecules are then split in the absence of a magnetic field. The origin of the splitting, as discussed above, is the anisotropy of the spin-spin interaction in molecules. In molecules containing atoms of large nuclear charge, spin-orbit interactions could lead to further splittings. We have neglected this interaction in the above discussion since we are considering molecules whose unpaired-electron distribution is largely localized on atoms of low atomic number and whose z.f. splittings are largely due to spin-spin interaction.

PRODUCTION OF THE STATE OF SPIN ALIGNMENT IN THE TRIPLET STATE

When a molecule changes its spin state from the lowest excited singlet state (S_1) to one of the triplet† state, T_k (T_1 is lowest energy, then T_2, \dots), it does so by exchanging its spin angular momentum with its orbital angular momentum. This leads not only to a change in the total spin angular momentum from $S = 0$ (singlet state) to $S = 1$ (triplet state), but also to a preferential spin direction in the molecular framework, depending on the symmetry of the spatial distribution of the excited electrons in S_1 and T_k . Different molecules might proceed to different triplet levels with different rates, depending on the magnitude of the spin-orbit interaction involved. Thus, it is possible that $S_1 \rightsquigarrow T_2$ leads to the spin direction τ_y (y could coincide with any of the molecular axes L, M or N), whereas $S_1 \rightsquigarrow T_1$ could lead to the spin direction τ_z . These processes take place in $\sim 10^{-7}$ to 10^{-9} sec, depending on the molecule. The molecule that selects to cross over to the triplet state via the $S_1 \rightsquigarrow T_2$ route loses its $E_{S_1} - E_{T_2}$ and then $E_{T_1} - E_{T_2}$ vibration-electronic energy (in $\sim 10^{-11}$ sec), and ends up in T_1 with the same spin direction τ_y , as long as the temperature is low so that the spin-lattice relaxation (s.l.r.) time between the different spin directions is longer than 10^{-11} sec. Those molecules which initially crossed to the T_1 electronic-vibrational levels with energy comparable to S_1 lose their vibration energy in $\sim 10^{-11}$ sec and end up in the τ_z spin z.f. level. Since the rate (or rate constant) of the $S_1 \rightsquigarrow T_1$ process would, in general, be different from that for the $S_1 \rightsquigarrow T_2$ process, the number of molecules reaching the τ_z level per unit time would be different from those reaching the τ_y z.f. level of the lowest triplet state. Molecules in the different z.f. levels of T_1 could return to S_0 by the phosphorescence process and/or by non-radiative processes with different rate constants. If excitation (pumping) and deactivating of the different z.f. levels of the lowest triplet state is taking place continuously, one may assume that the steady-state approximation holds. In the absence of s.l.r. (i.e. very low temperatures), one may obtain the following equations:

$$\frac{n_z}{n_y} = \frac{K_z k_y}{K_y k_z}, \frac{n_z}{n_x} = \frac{K_z k_x}{K_x k_z}, \text{ and } \frac{n_x}{n_y} = \frac{K_x k_y}{K_y k_x} \quad (1)$$

where n_z , K_z and k_z are the population density of the τ_z level, the rate constant for the non-radiative $S_1 \rightsquigarrow \tau_z$ intersystem crossing process, and the rate constant for the $\tau_z \rightsquigarrow S_0$ radiative and non-radiative processes, respectively.

If $K_z k_y \neq K_y k_z$, then $n_z \neq n_y$; and if $K_y k_x \neq K_x k_y$, then $n_y \neq n_x$, i.e. the steady-state populations (concentrations) of the spins in the three planes xy , yz and yz are not equal. The lowest triplet state is thus in a state of spin alignment in zero field. It is interesting to point out that the net anisotropy of the magnetization resulting in this situation is not induced by any external magnetic field, but rather is produced as a result of the anisotropy of the spin-orbit interactions in the molecule. Furthermore, the lowest energy magnetic level (τ_z in Figure 1) is not necessarily the most populated, since the Boltzmann

† T indicates the spatial (orbital) function, whereas τ_i indicates the spin function i of the triplet state.

distribution can only be reached if the s.l.r. processes are faster than the phosphorescence processes.

DECAY AT LOW AND HIGH TEMPERATURES

As the temperature increases, the s.l.r. processes become effective in coupling the different z.f. levels before they radiate. At temperatures above $\sim 10^\circ\text{K}$ a complete thermalization of the z.f. levels takes place, and the Boltzmann distribution is established. At these and higher temperatures, there is a slight temperature dependent degree of spin alignment due to the slight difference in the Boltzmann population of the three spin levels. The net spin direction in this situation can be predicted from a knowledge of the temperature and the z.f. splittings and thus gives no information concerning the mechanism of the intersystem crossing process. Thus, at temperatures for which the s.l.r. processes are faster than the radiative processes, the emitting triplet molecules lose memory about how they are made and the emitted radiation is useless as an informer about the non-radiative $S_1 \rightsquigarrow T_1$ intersystem crossing process. At these temperatures, the decay becomes exponential with only one decay constant^{1,8}, k , which is given by:

$$k = k_1\chi_1 + k_2\chi_2 + k_3\chi_3 \quad (2)$$

where k_i and χ_i are decay constant and the fraction population of the i th z.f. level. At 77°K , $\chi_i \approx 1/3$, then $k = (1/3)(k_1 + k_2 + k_3)$. If, as in pyrazine and many symmetrical aromatic hydrocarbons and their N -heterocyclics, one z.f. level has a much larger k than the other two, then $k = (1/3)k_s$, where k_s is the decay constant for the shortest-lived z.f. level at very low temperatures.

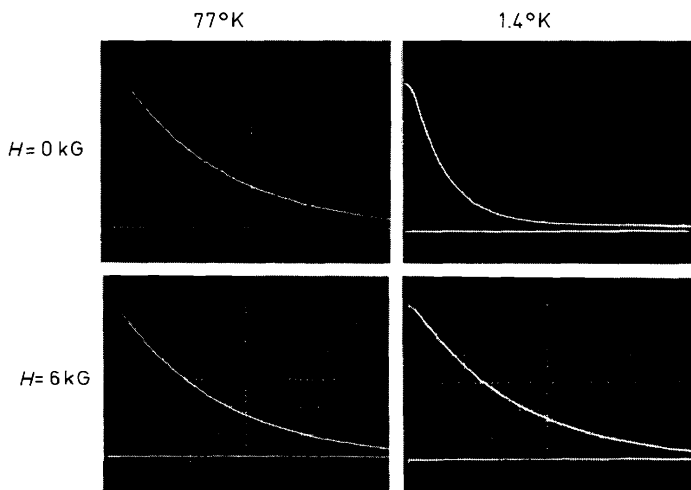

Figure 2. The effect of temperature and magnetic field on the phosphorescence decay of pyrazine- d_4 in cyclohexane. At 1.4°K or lower, the decay is non-exponential and could be resolved into three first-order decays with lifetimes of 6, 200 and ~ 500 msec, corresponding to the lifetimes of the three z.f. levels. As the temperature increases, the molecules relax their spin directions and the observed emission at 77° is that of the population-weighted average, rather than the sum, of the three z.f. levels. The decay becomes exponential with 18 msec lifetime (the time scale is 5 msec per division for all the four decays).

This is found to be true for quinoxaline¹, pyrazine² and other systems.

Thus at temperatures higher than 10°K, the properties of the emission from the lowest triplet state are those for a population-weighted average of the emission properties of the individual z.f. levels. If one of the z.f. levels has a much larger radiative rate constant, the emission properties of the other two z.f. levels would never be determined at high temperatures but could only be measured at the low temperature limit.

The non-exponential decay observed at very low temperatures can be changed to exponential decay by the application of high magnetic field. The strong mixing between the z.f. functions by the applied magnetic field equalizes their properties and rate constants^{2,9}, as well as assists the relaxation between them by increasing their energy separation, thus making use of the higher density of lattice vibration (phonons) present at higher frequencies¹. The effect of temperatures and magnetic field on the decay of pyrazine-d₄ cyclohexane is shown in *Figure 2*.

DETECTION AND USES OF THE STATE OF SPIN ALIGNMENT

Figure 3 is drawn for molecules whose emission results from different types of perturbations, e.g. spin-orbit and spin-orbit vibronic. Band (a) originates from

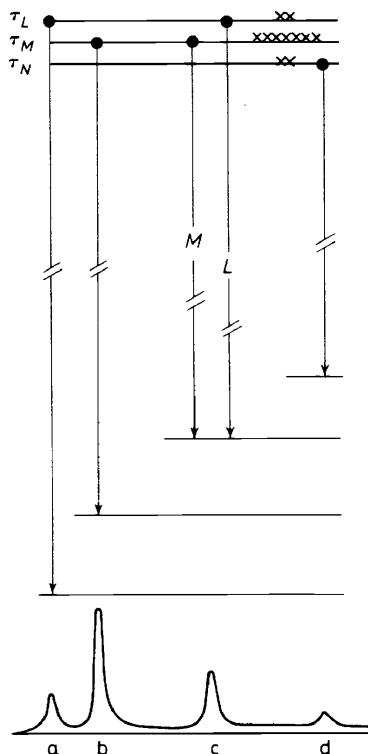

Figure 3. An energy level diagram and part of the emission spectrum drawn for a molecule in which the different vibronic bands have different z.f. origins.

MULTIPLE RESONANCE TECHNIQUES AND THE TRIPLET STATE

the top z.f. level (call τ_L) and band (b) originates from the middle z.f. level (call τ_M). Band (c) originates from τ_L and τ_M , whereas band (d) originates from τ_N . The rates of pumping and deactivating the z.f. levels are such that the middle z.f. level has a larger steady-state population at very low temperature. It is obvious that any perturbation that changes the population distribution given in *Figure 3* would have observable effects on the following phosphorescence properties:

- (1) The relative intensity of the vibronic bands in the spectrum
- (2) The polarization characteristics of the emission bands originating from the two different z.f. levels with different polarizations (e.g. band c)
- (3) The form of the decay curve.

The perturbations that could be applied to change the relative population density of the emitting levels are: (1) increasing temperature, (2) application of a magnetic field, (3) saturating any of the z.f. transitions (i.e. equalizing the population of any two of the z.f. levels involved) by microwave radiation of resonance frequencies.

The first⁵ and second perturbations^{1,2,9} could also change the non-exponential decay of the spin aligned triplet state into an exponential decay. The third perturbation will change the form of the decay in such a manner as to provide information concerning the z.f. origin(s) of a certain vibronic band⁷. The effect of these three perturbations on the phosphorescence spectrum of the 2,3-dichloroquinoxaline is shown in *Figure 4*.

It is obvious that the signs and magnitudes of the observed changes in the intensity, polarization and decay of any vibronic band in the spectrum, upon the application of the above perturbations, and in particular, the microwave radiation, could assist in identifying the z.f. origin(s) of the different vibronic bands, as will be shown later. On the other hand, the changes in the phosphorescence intensity could also be used to detect optically the z.f. transitions as was first demonstrated on the Zeeman transitions of these molecules by Sharnoff¹⁰ and others¹¹, and in z.f. by Schmidt and van der Waals¹². As a third application, we will also show that from the observed intensities of bands originating from different z.f. levels, with and without microwave saturation, one can determine the relative rates of the non-radiative intersystem crossing process to the different z.f. levels of the lowest triplet state. A discussion concerning the conservation of spin direction in triplet-triplet energy transfer is given at the end of the article.

MULTIPLE RESONANCE TECHNIQUES AND PHOSPHORESCENCE MECHANISM

If one would determine the phosphorescence z.f. origin of each vibronic band, the spin-orbit interactions responsible for the emission can be elucidated. From *Figure 3*, if one equalized the population of the τ_M and τ_N z.f. levels by saturating the $\tau_M \leftrightarrow \tau_N$ microwave transition, the intensity of the vibronic band (b) (originating from τ_M) would decrease, but that of the 0,0 [band (a)] would remain unaffected. However, if the $\tau_L \leftrightarrow \tau_M$ transition is saturated instead, the intensity of the 0,0 band increases but that originating from τ_M would remain unaffected. If the $\tau_L \leftrightarrow \tau_M$ transition is saturated, both bands (a) and (b) would change in intensity but with opposite signs [band (a) in *Figure 3* would increase but the vibronic band (b) would decrease].

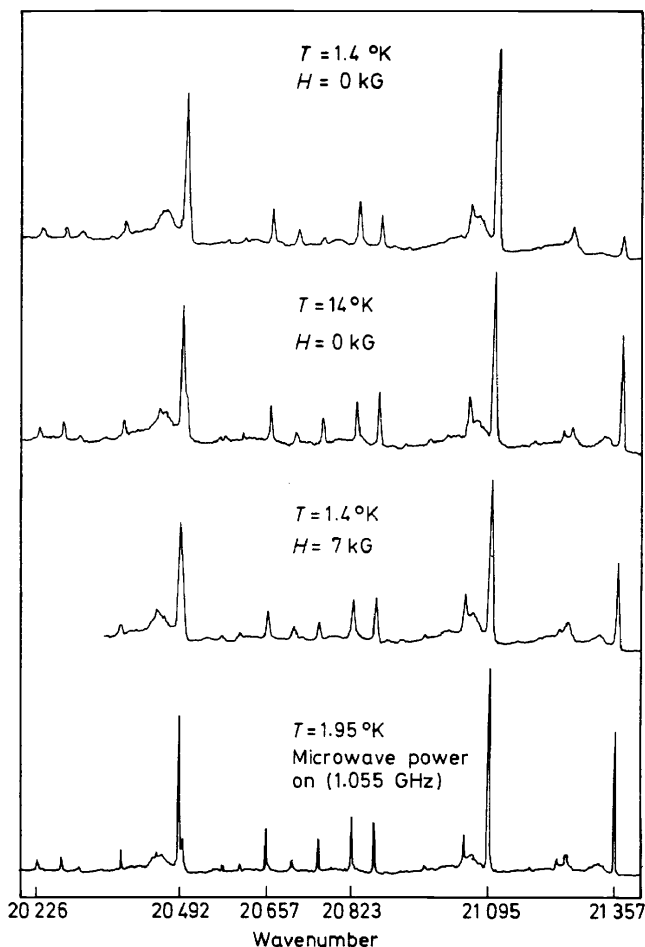

Figure 4. The phosphorescence spectra near the origin of 2,3-dichloroquinoxaline in a durene host polycrystal at low temperatures on application of different c.w. perturbations which influence the populations of the individual z.f. levels of the emitting triplet state. Note that high temperature, high magnetic field, or saturation of the τ_L - τ_M z.f. transition at 1.055 GHz leads to nearly identical relative vibronic intensities, showing that τ_N does not contribute significantly to the phosphorescence radiation. The top three spectra were taken on the 0.5 m instrument, while the 2 m instrument was used for the bottom spectrum.

Band (c) would change its polarization upon saturating any of the z.f. transitions, since the relative population of molecules emitting differently polarized radiation changes upon microwave saturation. From these observations, it is reasonable to conclude that the intensity of the 0,0 band [band (a)] originates from the τ_L z.f. level, that of the vibronic band (b) is from the τ_M z.f. level, and that of band (c) is of mixed origin.

Polarized modulated phosphorescence-microwave double resonance spectroscopy (am-PMDR)¹³

If one would modulate the microwave frequency with a certain frequency, ω_{12} , to which the detection system is locked, then one can measure the

MULTIPLE RESONANCE TECHNIQUES AND THE TRIPLET STATE

changes in the phosphorescence intensity of each band upon modulating the microwave radiation¹³. The modulation frequency cannot be larger than $1/\tau$, where τ is lifetime of the observed emission. If one scans the wavelength of the optical spectrometer, the sign of the change in intensity can be measured¹³

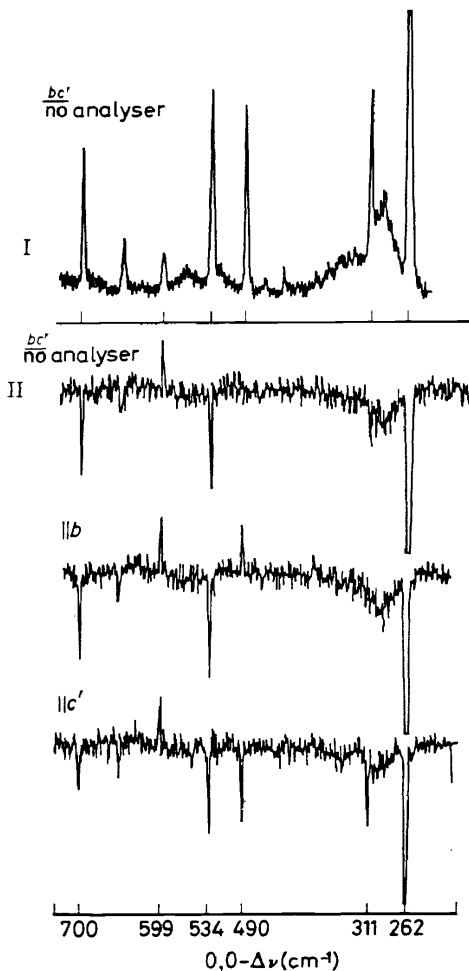

Figure 5. Part of the phosphorescence spectrum of 2,3-dichloroquinoxaline in durene at 1.6°K. I. Conventional spectrum. II. Amplitude-modulated phosphorescence-microwave double resonance (am-PMDR) spectrum, saturating the τ_L - τ_M transition at 1.055 GHz. The polarized am-PMDR spectra (bottom two) show the phosphorescence resolved into the sub-spectra that originate from the τ_L and τ_M z.f. levels.

for each band in the spectrum, as shown in the second spectrum from the top in *Figure 5* for the emission of 2,3-dichloroquinoxaline in durene. All bands having the same signs and relative magnitude comparable to their relative intensity in the conventional spectrum (top spectrum in *Figure 5*) must then originate from the same z.f. level. Bands whose intensity originates from different z.f. levels appear with opposite signs in the am-PMDR spectrum.

The band at $0.0\text{--}490\text{ cm}^{-1}$ originates from two z.f. levels. Its intensity does not change upon saturating these two levels. However, its polarization changes drastically. The effect of inserting a polarizer parallel to the two crystal axes is shown in the lower two spectra of *Figure 5*. The intensity of this band has opposite phases along the two polarization directions, indicating great changes in polarization with microwave saturation. From this type of spectrum obtained when the different z.f. transitions are saturated, a complete assignment of the z.f. origins of the different vibronic bands in the phosphorescence spectrum can be made.

The important conclusions obtained⁷ from this study concerning the mechanisms of the phosphorescence of 2,3-dichloroquinoxaline can be summarized as follows:

(1) In agreement with the spin-orbit interactions predicted in this molecule, only two of the three z.f. levels are strongly radiative.

(2) The agreement between theory and observation is improved if spin-orbit interactions occur between singlet and triplet states of different electronic type, e.g. $S_{n,\pi^*} \rightsquigarrow T_{\pi,\pi^*}$ or $S_{\pi,\pi^*} \rightsquigarrow T_{n,\pi^*}$.

(3) Interactions involving vibronic, as well as spin-orbit, perturbations are found to be more effective in rendering the π,π^* triplet state its radiative properties than those involving only spin-orbit perturbation.

(4) The substitution of a halogen for a hydrogen atom in an aromatic compound is found to decrease the observed phosphorescence lifetime due to the enhanced spin-orbit interaction when the π -electron 'feels' the large nuclear change of the halogen. Previous observations were made on phosphorescence observed at 77°K . Thus, it was never discussed in terms of the intramolecular heavy-atom effects on the individual z.f. levels of the lowest triplet state. *Table 1* compares the lifetimes of the different z.f. levels of quinoxaline- d_6 with the corresponding ones for its 2,3-dichloro derivative. The

Table 1. Comparison of the phosphorescence lifetimes (in seconds) of the individual z.f. levels for quinoxaline- d_6 and 2,3-dichloroquinoxaline

Zero field level	Quinoxaline- d_6 †	2,3-Dichloroquinoxaline
τ_L	0.15 ± 0.02	0.34 ± 0.03
τ_M	≥ 3.6	0.14 ± 0.01
τ_N	≥ 4.2	≥ 2.5

†J. Schmidt, W. S. Veeman and J. H. van der Waals, *Chem. Phys. Letters*, **4**, 341 (1969).

change in the observed lifetime (lifetime = $1/k$) at 77°K is only by a factor of 0.7. From *Table 1*, the observed change in the lifetime of the middle z.f. level is by a factor of 0.04. It thus seems that while the chlorine atom effect on the observed population-weighted average of the observed lifetime of quinoxaline is very small, its effect on one of the z.f. levels is extremely large and was almost undetected at 77°K . It is also interesting to point out that a 'negative heavy-atom effect' is observed for the top z.f. levels of quinoxaline, whose lifetime increases, instead of decreases, upon halogen substitution.

(5) The overall heavy-atom effect on the lifetime of quinoxaline is much less pronounced than that for its parent hydrocarbon, naphthalene. The life-

time of naphthalene- d_8 decreases from 30 sec to ~ 0.1 sec for halonaphthalene. This is due to the fact that quinoxaline lifetime, being ~ 0.5 sec, has already been decreased sufficiently by the strong spin-orbit interaction between its singlet n,π^* and triplet π,π^* states. Thus, as was previously indicated¹⁴, the observed large heavy-atom effects on the aromatic hydrocarbon phosphorescence is a result of the weak spin-orbit interaction in these molecules¹⁵.

(6) Experimentally, the spin-orbit interaction energy between the lowest triplet state π,π^* in 2,3-dichloroquinoxaline and its lowest n,π^* singlet state is found to be at least ten times larger than that of the lowest energy π,π^* singlet state.

(7) In 2,3-dichloroquinoxaline, and probably in all molecules with an emitting π,π^* triplet state, the spin-vibronic interactions {resulting from the $[(\partial H_{so})/(\partial Q_a)]Q_a$ terms in the Hamiltonian} are not as effective as the spin-orbit interactions nor as the interactions involving second-order spin-orbit and vibronic perturbations in rendering the triplet state its radiative properties.

(8) In pyrimidine, whose emitting state is of the n,π^* type, spin-vibronic interactions with S_{π,π^*} states seem to compete weakly with the spin-orbit interactions in rendering the triplet state its radiative properties.

OPTICAL DETERMINATION OF MAGNETIC TRANSITIONS IN ZERO FIELD

(a) Zero field transition

It is obvious that by scanning the microwave, the phosphorescence intensity from a certain z.f. level would change when the microwave frequency becomes in resonance with a z.f. transition involving the emitting level. This was first demonstrated by monitoring the total intensity of a molecule whose emission results from one z.f. level¹⁵. For a molecule with more than one radiative z.f. level (e.g. haloaromatic), a vibronic band is monitored whose emission originates mostly from the z.f. level being perturbed by the microwave⁶. *Figure 3* illustrates the principle of determining z.f. spectrum optically for this type of molecule. If we are using the long wavelength band [band (d)] to monitor the detection of the z.f. transitions, it is obvious that both $\tau_L \leftrightarrow \tau_N$ and $\tau_M \leftrightarrow \tau_N$ transitions could be detected optically. However, the $\tau_M \leftrightarrow \tau_L$ transitions could be determined if either band (a) or band (b) is monitored while the microwave frequency is scanned. Thus for molecules whose emission originates from more than one z.f. level, the energies of all three transitions can be determined⁶, at least in principle.

Figure 6 shows the type of microwave z.f. spectrum for 2,3-dichloroquinoxaline obtained⁶ by optical detection. The observed structure results from the nitrogen (nuclear spin = 1) hyperfine structure. This gives rise to simultaneous electron-nuclear spin transitions in zero field. This spectrum is thus important in determining hyperfine and nuclear quadrupole parameters in the excited triplet state.

It should be pointed out that the sensitivity of the optical methods of determination of z.f. transitions is not limited to molecules of long triplet lifetime, as is the case for e.s.r. methods. This can be seen from equation 3 which expresses the fractional change in the phosphorescence intensity upon

microwave saturation of one of the $\tau_i \leftrightarrow \tau_j$ z.f. transitions. If I^v and I designate the phosphorescence intensity of the emission from the τ_i z.f. level with and without microwave saturation of the $\tau_i \leftrightarrow \tau_j$ z.f. transition, then¹⁶

$$\frac{I^v}{I} = \frac{K_i + K_j k_i}{k_i + k_j K_i} \quad (3)$$

where K and k are the rate constants for the pumping and decay processes of the lowest triplet state. The optical method of detecting z.f. transitions is

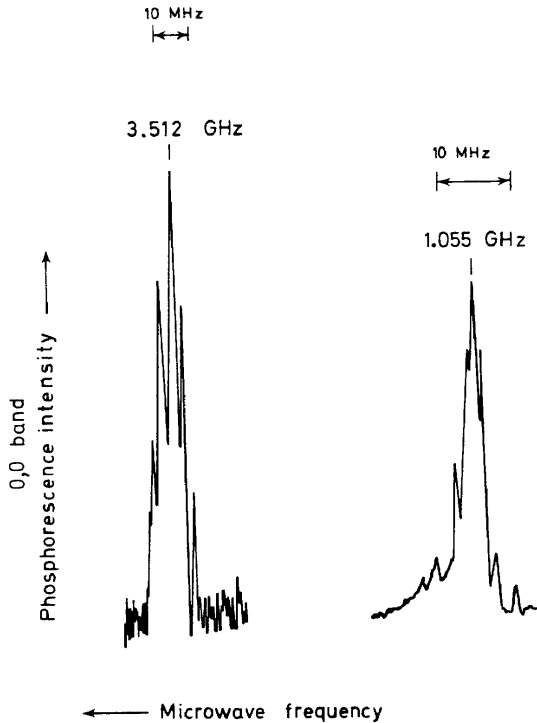

Figure 6. The microwave spectrum of the $\tau_L \leftarrow \tau_M$ (right) and $\tau_L \leftarrow \tau_N$ (left) z.f. transitions of 2,3-dichloroquinoxaline in durene, as monitored by detecting the changes of the 0,0 band intensity of the ${}^3B_{2u}^{n,n*} \rightarrow {}^1A_1$ phosphorescence at 1.9°K as the microwave frequency changes.

most sensitive if the above ratio on the RHS of equation 3 is either much greater or much smaller than unity. From this equation, the lifetime = $1/k_i$ itself is not important; but its value relative to the other rate constants is important.

(b) Assignment of z.f. transition by optical detection

The e.s.r. methods are capable of not only determining the energies of the z.f. transitions, but also of assigning the z.f. transitions from the dependence of the observed magnetic spectrum of single crystals on the field direction. In optical methods, polycrystalline powder can be used to determine the

MULTIPLE RESONANCE TECHNIQUES AND THE TRIPLET STATE

energies of the z.f. transitions in a more convenient manner than the e.s.r. methods. But the assignment of these transitions could not be made by optical means until an optical method is devised¹⁷ by which the polarization of these magnetic transitions is determined in z.f. A single crystal in which the molecule to be studied is dissolved substitutionally, is oriented with one of the crystal axes, l , parallel to the microwave helix axis (the magnetic field direction of the microwave radiation). The changes in the intensity of the phosphorescence from the z.f. level i is thus recorded as a function of the power P of the microwave radiation which is in resonance with the $\tau_i \leftrightarrow \tau_j$ z.f. transition. Using the steady-state approximation and if the temperature is low enough to assure the absence of the spin-lattice relaxation, the following equation can be derived¹⁷

$$\left(\frac{dP}{dI_i}\right)_l = \frac{k_i}{k_i'(\sigma_{ij})_l \Delta n} + \frac{k_i + k_j}{k_i' k_j} \frac{1}{\Delta n} P \quad (4)$$

where $(\sigma_{ij})_l$ is the microwave absorption cross section of the $\tau_i \leftrightarrow \tau_j$ transition, and $\Delta n (= n_j - n_i)$ is the population difference between the two levels being saturated. At low microwave powers, Δn could be assumed constant and equation 4 becomes that for a straight line, whose slope/intercept is proportional to σ . If $(dP/dI)_l$ is plotted versus P when the crystal axis l is parallel to the helix direction, as well as when the crystal axis m is parallel to the helix direction, then the value of the σ_l/σ_m (polarization ratio) can be determined from

$$\frac{(\sigma_{ij})_l}{(\sigma_{ij})_m} = \frac{(\text{slope/intercept})_l}{(\text{slope/intercept})_m} \quad (5)$$

By comparing the observed polarization ratios with those predicted from the oriented gas model, an assignment of the symmetry of the z.f. transition could be made.

In conclusion, the determination of z.f. transitions by optical methods has the following advantages over conventional e.s.r. techniques:

(1) The energies are determined in a more convenient manner, where alignment problems and the magnetic field are eliminated.

(2) Short radiative lifetime results in smaller steady-state population and thus diminishes the e.s.r. signal. However, short radiative lifetimes mean stronger phosphorescence intensities. This makes the sensitivity of the optical methods not to be directly dependent on the radiative lifetime.

There are disadvantages to the optical detection methods, the most serious of which is the need to work at very low temperatures. This difficulty might soon disappear if more efforts toward sensitive detection are made. Work in this direction is now in progress.

(c) Optical detection of electron-electron double resonance in zero field¹⁷

For molecules whose emission originates from only one z.f. level, e.g. symmetrical aromatic hydrocarbons and their N -heterocyclics, optical

methods could only determine the two z.f. transitions involving the emitting level at very low temperatures. In order to determine the third transition, an electron–electron double resonance experiment has to be performed¹⁸. Let us assume the three levels are τ_1 , τ_2 and τ_3 . If τ_1 is the only emitting level, then the saturation of the $\tau_2 \leftrightarrow \tau_3$ transition at low temperature would induce no change in the population of the emitting level τ_1 . However, if the $\tau_1 \leftrightarrow \tau_2$ transition is continuously saturated with microwave radiation ν_1 and another microwave sweeper is being swept, the population of the emitting τ_1 level changes, and a corresponding change in the phosphorescence intensity from I_{ν_1} to I_{ν_1, ν_2} is observed, when the frequency of the variable frequency microwave ν_2 is equal to $(E_2 - E_3)/\hbar$. The following equation¹⁶ shows the sensitivity of the EEDOR method

$$\frac{I_{\nu_1, \nu_2}}{I_{\nu_1}} = \frac{K_1 + K_2 + K_3}{K_1 + K_2} \frac{k_1 + k_2}{k_1 + k_2 + k_3} \quad (6)$$

It should be pointed out that EEDOR method is also useful in determining z.f. transition energy between two levels, e.g. $\tau_1 \leftrightarrow \tau_2$ whose steady population is the same in the absence of microwave. If one would disturb this equality by saturating the $\tau_2 \leftrightarrow \tau_3$ or the $\tau_1 \leftrightarrow \tau_3$ transition, then scanning the $\tau_1 \leftrightarrow \tau_2$ energy region, the latter transition could be detected.

(d) Optical detection of electron–nuclear double resonance transition in zero field^{19,20}

If a molecule contains an atom with a nucleus having nuclear spin $I > 1/2$, e.g. N or Cl, the observed microwave spectrum will be more complex due to the electron–nuclear hyperfine interaction as well as nuclear quadrupole interactions. For each of the three electron–spin directions, there are a number of different nuclear spin quantized directions. For nitrogen, $I = 1$, each electron spin level has three different nuclear spin directions. The intersystem crossing processes ($S_1 \rightsquigarrow T_1$ and $T_1 \rightarrow S_0$) are determined by the electron–spin–electron–orbit interactions. If the rate of formation of the different z.f. states of the triplet state from S_1 is too fast as compared to the nuclear spin re-orientation time in the magnetic field of the two unpaired electrons, then nuclear polarization will not be produced in the intersystem crossing process. Thus the steady-state population is expected to be equal for the different nuclear spin levels belonging to the same electron spin level at very low temperatures in zero field. If this is true, then the nuclear transitions in any z.f. level of the triplet state could not be optically detected directly since the corresponding levels would have equal populations and their transitions would not have net radiowave absorption. One can, however, make use of the difference in population of the different z.f. (electron spin) levels. If one saturates two electron–nuclear spin levels continuously with microwave radiation, then the nuclear levels being saturated would have different populations from the other nuclear levels in the same z.f. manifold. If a radio-frequency sweeper is then used, net absorption would occur, and a corresponding change in the phosphorescence intensity would be observed, at frequencies corresponding to nuclear transitions between the nuclear spin levels being

MULTIPLE RESONANCE TECHNIQUES AND THE TRIPLET STATE

saturated with microwave and other nuclear spin levels in the same z.f. manifold. The sensitivity of the optical methods in detecting ENDOR transitions can be predicted from the following expression¹⁶.

$$\frac{I_{v,v'}}{I_v} = \frac{6 k_1 K_1 + 2 k_1 K_2 + k_2 K_1}{3 k_1 K_1 + k_1 K_2 + 2 k_2 K_1} \times \frac{k_1 + k_2}{2 k_1 + k_2} \quad (7)$$

where I_v is the phosphorescence intensity of the emission from z.f. level, when a pure electron spin transition between z.f. level 1 and 2 is saturated and $I_{v,v'}$ is the intensity of the emission from z.f. level 1 when, in addition, a nuclear transition in z.f. level 1 is saturated; k and K were defined previously. A number of interesting limits have been discussed elsewhere¹⁶.

It is thus obvious that the energies required to change the direction of the nuclear spin in the field of the electron spin can be determined optically in zero field. This is an optically detected n.m.r. type experiment whereby the laboratory field is replaced by the field of the two unpaired spins (z.f.) in the molecular framework. The ENDOR frequencies are important in determining hyperfine and quadrupole parameters in the excited triplet state^{19,20}.

MULTIPLE RESONANCE TECHNIQUES AND NON-RADIATIVE PROCESSES INVOLVING THE TRIPLET STATE

(A) $S_1 \rightsquigarrow T_1$ intersystem crossing

The intensity of the emission from level i , I_i , is given by

$$I_i = k_i^r n_i \quad (8)$$

where k_i^r is the radiative decay constant of the z.f. level i . If one saturates, say, the $\tau_1 \leftrightarrow \tau_2$ transition, thus

$$n_1^v = n_2^v \quad \text{and} \quad \frac{I_1^v}{I_2^v} = \frac{\gamma_1 k_1^r n_1^v}{\gamma_2 k_2^r n_2^v} = \frac{\gamma_1 k_1^r}{\gamma_2 k_2^r} \quad (9)$$

where γ_1 and γ_2 are the fractions of the total intensity emitted from z.f. levels 1 and 2, respectively, that appear in the bands used for monitoring the corresponding emission. Since in the absence of the microwave:

$$I_1/I_2 = \gamma_1 k_1^r n_1 / \gamma_2 k_2^r n_2 \quad (10)$$

$$\therefore (I_1^v/I_2^v)/(I_1/I_2) = n_2/n_1 \quad (11)$$

substituting from equation 1 for n_2/n_1

$$(I_1^v/I_2^v)/(I_1/I_2) = (K_2 k_1)/(K_1 k_2) \quad (12)$$

Since k_1 and k_2 are the observed decay constants of levels τ_1 and τ_2 and could be measured experimentally, equation 12 might then be used²¹ to determine the ratio of the intersystem crossing rate constants to the τ_1 and τ_2 z.f. levels. This can be accomplished²¹ by measuring the intensity of the emission from the τ_1 and τ_2 z.f. levels with and without microwave saturation of the z.f. $\tau_2 \leftrightarrow \tau_1$ transition. The ratios K_1/K_3 and K_2/K_3 can be determined in a similar manner.

From these ratios, one determines the spin direction in the molecular framework which most of the molecules possess following the intersystem crossing process from S_1 . From the symmetry of S_1 one may conclude the spatial symmetry of the triplet state, of lower energy than S_1 , to which the molecule must cross, so that the group theoretically predicted spin direction in the molecule would coincide with the one determined experimentally. In this simplified manner, the mechanism of the intersystem crossing process might be elucidated.

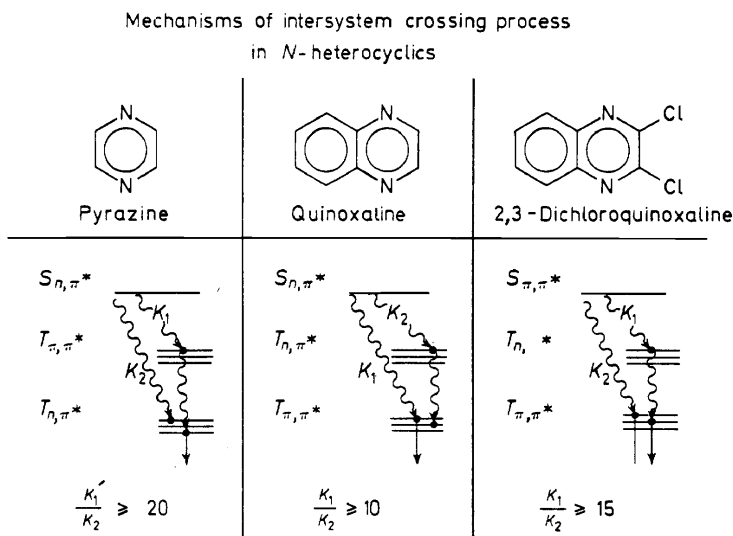

Figure 7. Experimentally determined ratios for the rate constants of the first-order non-radiative $S_1 \rightsquigarrow T_1$ (intersystem crossing) processes in some nitrogen heterocyclics. The intersystem crossing processes seem to favour the simultaneous exchange of the spin angular momentum (in the singlet \rightarrow triplet transition) with the electronic orbital type (e.g. $n \leftrightarrow \pi$), as was previously qualitatively shown²² from theory.

A number of molecules have been studied. *N*-heterocyclics are probably the most useful series since comparison of results with theory can be made. As was pointed out previously²², in these molecules the most probable route for the intersystem crossing is the one in which the spin change is accompanied by a change in the electron orbital-type, e.g. $S_{n,\pi^*} \rightsquigarrow T_{\pi,\pi^*}$ or $S_{\pi,\pi^*} \rightsquigarrow T_{n,\pi^*}$. Four molecules have been studied: quinoxaline, 2,3-dichloroquinoxaline⁷, pyrazine²³ and pyrimidine¹⁸. The energy levels and the experimentally determined most probable intersystem crossing processes for three of these molecules are indicated in Figure 7. It is interesting to point out that in all the mechanisms shown in Figure 7, the above mentioned selection rules are followed. The experimentally determined ratios of the rate constants shown in Figure 7 lead to the conclusion that the process $S_{\pi,\pi^*} \rightsquigarrow T_{n,\pi^*}$ or $S_{n,\pi^*} \rightsquigarrow T_{\pi,\pi^*}$ is at least one order of magnitude more probable than $S_{\pi,\pi^*} \rightsquigarrow T_{\pi,\pi^*}$ or $S_{n,\pi^*} \rightsquigarrow T_{n,\pi^*}$. This is in agreement with previous theoretical predictions²².

(B) Triplet-triplet energy transfer

In triplet-triplet energy transfer, the total spin is conserved, i.e.

$$S_A + T_D = S_D + T_A \quad (13)$$

where A and D denote the acceptor and the donor molecules, respectively, and S and T refer to their multiplicities.

Suppose one can prepare the triplet state of the donor with a unique spin direction in the donor molecule framework, i.e. with only one of its three z.f. levels being populated. The following question would then arise. What would be the direction of the electron spins in the acceptor molecular framework after the energy transfer process takes place? If the donor spin direction results from the molecules being in the τ_i^D z.f. level, then the population of the different spin directions, say 1, 2 and 3, of the acceptor will be proportional¹⁶ to $\cos^2 \theta_{1,i}$, $\cos^2 \theta_{2,i}$ and $\cos^2 \theta_{3,i}$, respectively, where $\theta_{i,1}$ is the angle between the principal magnetic axes corresponding to the τ_i^D and that for the τ_1^A . Thus, if the relative orientations of the principal magnetic axes of the donor and acceptor molecules are known and if one knows the direction of the spin alignment in the donor, one can predict the direction of the spin alignment produced in the acceptor by triplet-triplet energy transfer. The above theoretical prediction¹⁶ is based on the fact that the interaction leading to the energy transfer is electrostatic²⁴ (of the exchange type) and not magnetic, and thus should have no effect on the spin direction of the donor. This means that after the transfer, the observed spin directions in the acceptor are those resulting from projecting the spin direction in the donor on the principal magnetic axes of the acceptor. If the donor and the acceptor molecules have their corres-

Triplet-triplet energy transfer between individual zero-field levels

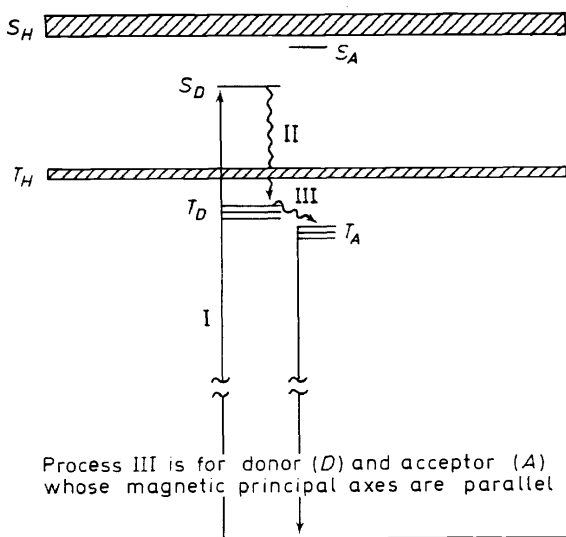

Figure 8. The energy level diagram of the system studied to show that the spin direction is conserved in the triplet-triplet intermolecular energy transfer process between quinoxaline and $C_{10}H_8$ traps at 1.4°K.

ponding principal magnetic axes parallel to one another, the spin direction of the triplet state of the acceptor after the transfer should be parallel to that of the donor triplet state before the transfer.

These predictions have been verified²⁵ experimentally by using the microwave-phosphorescence double resonance techniques. The energy level diagram of the system used is shown in *Figure 8*. The donor is quinoxaline and the acceptor is the naphthalene ($C_{10}H_8$) molecules located next to quinoxaline in a $C_{10}H_8$ crystal. The triplet energy of the $C_{10}H_8$ crystal (T_H) is slightly above that of quinoxaline (T_D) but the triplet state of the naphthalene molecules next to quinoxaline has slightly lower energy (T_A) than that of quinoxaline. The 366 nm Hg line excites the quinoxaline but not the naphthalene. No quinoxaline phosphorescence is observed in $C_{10}H_8$ due to the transfer to the $C_{10}H_8$ traps (T_A). Microwave radiation is found to decrease the phosphorescence intensity of these traps upon saturation of both the $\tau_L \leftrightarrow \tau_M$ and the $\tau_L \leftrightarrow \tau_N$ transitions. Since the emission originates from the τ_L level, these results indicate that triplet-triplet energy transfer favours populating the τ_L z.f. level. If quinoxaline is dissolved in $C_{10}D_8$ instead, its emission is observed. This is due to the fact that deuteration blue shifts the $S-T$ transitions of $C_{10}D_8$ above that for quinoxaline. Microwave-phosphorescence double resonance studies showed that τ_L is formed with highest probability when quinoxaline is excited with the 366 nm Hg line. Thus, the transfer takes place between $(\tau_L)_D$ and the $(\tau_L)_A$ in the $C_{10}H_8$ crystal. This is expected, since the long axes of $C_{10}H_8$ and quinoxaline in non-equivalent sites (where the transfer probability is largest) are parallel to one another in the $C_{10}H_8$ crystal. Energy transfer between molecules in equivalent sites might also take place with less probability than that between molecules in non-equivalent sites; but since molecules in equivalent sites are parallel to each other, it is obvious that the transfer will take place between $(\tau_L)_D \leftrightarrow (\tau_L)_A$.

FUTURE APPLICATION OF MULTIPLE RESONANCE TECHNIQUES TO PHOTOCHEMISTRY

Does the rate and yield of a solid-state photochemical reaction involving the triplet state depend on the net direction of the spins in a spin-aligned state? To answer this question, let us discuss the reaction between atoms with unpaired electrons. The reaction

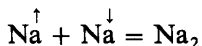

is exothermic, and thus its equilibrium constant should decrease by increasing the temperature. In the presence of a magnetic field, a fraction of the atoms would have parallel spins, due to the spin alignment in the presence of the magnetic field. This fraction of atoms would not react to give Na_2 . At higher temperatures, a smaller fraction of atoms would have parallel spins and the number of successful collisions leading to the reaction increases. Thus, in the presence of high magnetic fields, temperature increase could lead²⁶ to an increase in the equilibrium constant of the above reaction. In molecules, spin alignment in the triplet state could occur in zero field at low temperatures, as shown in this article. In the solid state, the rate of the reaction between two triplets or a triplet state and an atom in a magnetic field or in the absence of a

field, depending upon the mode of its formation in the solid, could be sensitive to the direction of the net spin direction of the triplet state. Since the direction of the net spin direction of the triplet state can be changed by microwave saturation of the z.f. transitions at very low temperatures, it is possible for multiple resonance techniques to be used to control the rate of the photochemical reaction. Furthermore, an accurate understanding of the mechanism of bond formation or breaking in solid-state photochemical reactions might be obtained by examining the effect of saturating the different z.f. transitions on the rate and yield of the photochemical reaction under examination.

ACKNOWLEDGEMENTS

The author wishes to thank Drs Harris, Kalman, Kuan, Maki, Moomaw and Tinti and Messrs L. Hall and D. Owens for their very fruitful collaboration. The support of the Office of Naval Research of parts of this work is gratefully acknowledged.

REFERENCES

- ¹ M. S. deGroot, I. A. M. Hesselmann and J. H. van der Waals, *Molec. Phys.* **12**, 259 (1967).
- ² L. Hall, A. Armstrong, W. R. Moomaw and M. A. El-Sayed, *J. Chem. Phys.* **48**, 1395 (1968).
- ³ M. A. El-Sayed, W. R. Moomaw and D. S. Tinti, *J. Chem. Phys.* **50**, 1888 (1969).
- ⁴ M. Schwoerer and H. C. Wolf, *Proceedings of the XIVth Colloque Ampère*, p 87. R. Blinc, Ed. North Holland; Amsterdam (1967);
M. Schwoerer and H. Sixl, *Chem. Phys. Letters*, **2**, 14 (1968); *Z. Naturforschung*, **24**, 952 (1969).
- ⁵ M. A. El-Sayed, D. S. Tinti and D. Owens, *Chem. Phys. Letters*, **3**, 339 (1969).
- ⁶ D. S. Tinti, M. A. El-Sayed, A. H. Maki and C. B. Harris, *Chem. Phys. Letters*, **3**, 343 (1969).
- ⁷ D. S. Tinti and M. A. El-Sayed, presentation at the International Conference on Molecular Luminescence (Newark, Delaware, August 1969), *J. Luminescence*, **1**, 166 (1970);
D. S. Tinti and M. A. El-Sayed, "New techniques in triplet state phosphorescence spectroscopy", *J. Chem. Phys.*, in press; M. A. El-Sayed, D. S. Owens and D. S. Tinti, 'Polarized modulated PMDR and the zero-field origin of phosphorescence', *Chem. Phys. Letters*, **6**, 395 (1970).
- ⁸ T. Azumi, C. M. O'Donnell and S. P. McGlynn, *J. Phys. Chem.*, **45**, 2735 (1966).
- ⁹ L. Hall, D. Owens and M. A. El-Sayed, *J. Chem. Phys.*, to be published.
- ¹⁰ M. Sharnoff, *J. Chem. Phys.* **46**, 3263 (1967).
- ¹¹ (a) A. Kwiram, *Chem. Phys. Letters*, **1**, 272 (1967).
(b) J. Schmidt, I. A. M. Hesselmann, M. S. deGroot and J. H. van der Waals, *Chem. Phys. Letters*, **1**, 434 (1967).
- ¹² J. Schmidt and J. H. van der Waals, *Chem. Phys. Letters*, **2**, 640 (1968).
- ¹³ M. A. El-Sayed, D. S. Owens and D. S. Tinti, 'Polarized modulated PMDR spectroscopy and the zero-field origin of phosphorescence', *Chem. Phys. Letters*, **6**, 395 (1970).
- ¹⁴ M. A. El-Sayed, *J. Chem. Phys.* **43**, 2864 (1965).
- ¹⁵ D. S. McClure, *J. Chem. Phys.* **20**, 682 (1952).
- ¹⁶ M. A. El-Sayed, 'Optical pumping of the lowest triplet state and multiple resonance optical techniques in zero field', *J. Chem. Phys.*, in press.
- ¹⁷ M. A. El-Sayed and O. F. Kalman, *J. Chem. Phys.* **52**, 4903 (1970).
- ¹⁸ T. S. Kuan, D. S. Tinti and M. A. El-Sayed, *Chem. Phys. Letters*, **4**, 507 (1970).
- ¹⁹ C. B. Harris, D. S. Tinti, M. A. El-Sayed and A. H. Maki, *Chem. Phys. Letters*, **4**, 409 (1969).
- ²⁰ I. Y. Chan, J. Schmidt and J. H. van der Waals, *Chem. Phys. Letters*, **4**, 269 (1969).
- ²¹ M. A. El-Sayed, *J. Chem. Phys.* **52**, 6438 (1970).
- ²² M. A. El-Sayed, *J. Chem. Phys.* **38**, 2834 (1963).
- ²³ M. A. El-Sayed, Proceedings, International Conference on Molecular Luminescence, p 715. Loyola University, Chicago, Illinois, 1968, E. Lim, Ed. Benjamin: New York (1969).
- ²⁴ D. L. Dexter, *J. Chem. Phys.* **21**, 836 (1953).
- ²⁵ M. A. El-Sayed, D. S. Tinti and E. M. Yee, *J. Chem. Phys.* **51**, 5721 (1969).
- ²⁶ A. Kastler, *Acta Phys. Polonica*, **34**, 693 (1968).